

08th
EDITION

Installation & Operation Manual

L13 Series Engines

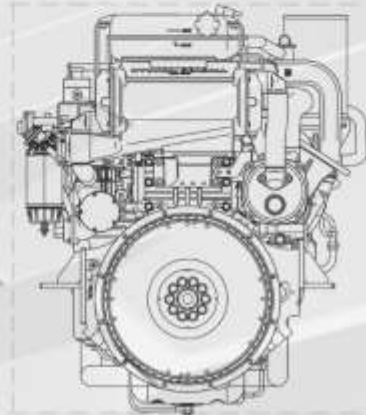
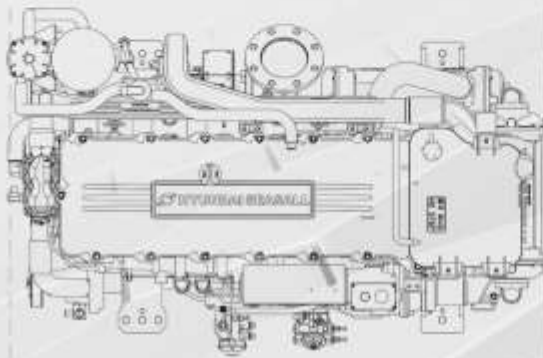
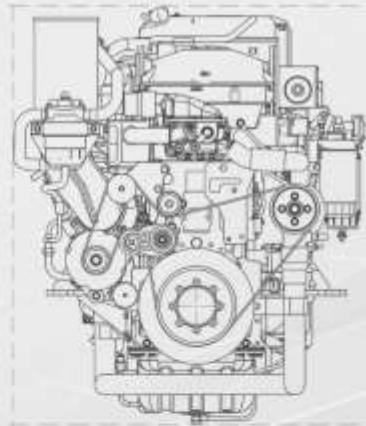
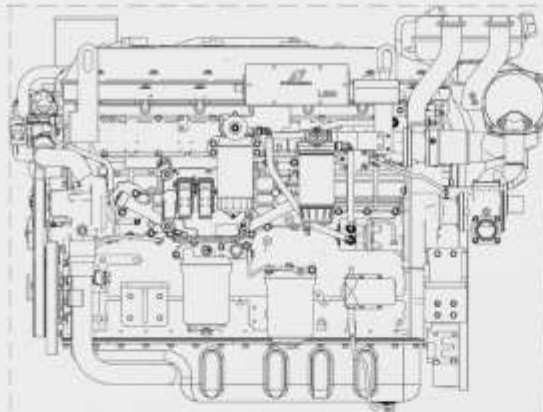

TABLE OF CONTENTS

ABOUT THIS MANUAL	3
SAFETY PRECAUTIONS	4
APPROXIMATE STANDARD CONVERSIONS	6
CHAPTER 1 ENGINE OVERVIEW	7
ENGINE COMPONENTS	7
TECHNICAL DATA	9
PERFORMANCE CURVES.....	10
ENGINE IDENTIFICATION.....	11
ENGINE HANGER.....	12
ENGINE DIMENSIONS.....	13
CHAPTER 2 ENGINE OPERATION	15
STARTING AND STOPPING ENGINE.....	15
EMERGENCY STOP	16
INTAKE AIR HEATER.....	16
CHAPTER 3 COOLING SYSTEM	17
SCHEMATIC DIAGRAM OF ENGINE COOLING CIRCUIT	17
SEAWATER FLOW – OPENED COOLING CIRCUIT.....	18
WATER PICKUP.....	18
WATER STRAINER.....	18
CLEANING STRAINER FILTER.....	19
AUTOMATIC DRAIN VALVE.....	20
SEAWATER PUMP.....	21
CHECKING SEAWATER PUMP & IMPELLER.....	22
ENGINE COOLANT FLOW – CLOSED COOLING CIRCUIT	23
ENGINE COOLANT.....	23
SUPPLEMENTAL ENGINE COOLANT.....	24
DRAINING COOLANT.....	24
REMOVING AIR BUBBLES IN COOLANT.....	25
CABIN HEATER CONNECTION.....	25
CHAPTER 4 FUEL SYSTEM	26
EUI SYSTEM.....	26
FUEL SUPPLY SYSTEM.....	27
FUEL LINE.....	27
RECOMMENDED FUEL QUALITY	28
DRAINING WATER FROM FUEL FILTER	28
CHANGING FUEL FILTER	29
CHAPTER 5 INTAKE & EXHAUST SYSTEM	30
ENGINE AIR CONSUMPTION & ROOM VENTILATION	31
CHECK AIR FILTER	32
CLEANING AIR FILTER	32
EXHAUST SYSTEM.....	33
CHAPTER 6 LUBRICATION SYSTEM	34
LUBRICATION COMPONENTS.....	34
ENGINE OIL LEVEL CHECKS.....	35

TABLE OF CONTENTS

RECOMMENDED OIL QUALITY.....	35
ENGINE OIL EXTRACTION PUMP.....	36
CHECKING OIL FILTER.....	36
CHAPTER 7 ELECTRICAL SYSTEM	37
BATTERY CABLE CONNECTIONS	37
ACCELERATION SENSOR AND CONTROL LEVER.....	38
PROCEDURES FOR CONTROL LEVER INSTALLATION.....	38
BATTERY CHECKS.....	39
LOAD TEST.....	39
FUSES AND RELAYS.....	40
SYSTEM FUSE BOX.....	40
FUSE BOX.....	40
FUSES.....	40
RELAYS.....	41
CHAPTER 8 EOI SYSTEM	42
INSTRUMENT CONNECTIONS.....	42
RPM GAUGE.....	43
USER INTERFACE.....	43
EOI FUNCTION.....	44
LCD INFORMATION.....	44
WARNING LAMP.....	45
SWITCHES	46
PTO MODE.....	46
IDLE SETTING MODE.....	46
EOI BOX (INSIDE).....	47
CUT OUT FOR EOI SYSTEM.....	47
EOI PIN ASSIGNMENT.....	48
SEASLINK PRODUCT COMPONENTS.....	50
INSTALLATION OF SEASLINK DONGLE.....	51
G-SCAN.....	52
G-SCAN CONNECTIONS.....	52
DTC (DIAGNOSIS TROUBLE CODE) AND ALARM LIST.....	53
CHAPTER 9 ANTI CORROSION SYSTEM	57
CHAPTER 10 ENGINE STORAGE	58
WINTER STORAGE.....	59
LONG TERM STORAGE.....	60
CHAPTER 11 MAINTENANCE	61
THE INITIAL RUNNING CHECK.....	61
MAINTENANCE SCHEDULE	62
A/S PART NUMBER.....	63
MAINTENANCE LOG.....	64
CHAPTER 12 TROUBLESHOOTING GUIDE	65
CHAPTER 13 WARRANTY	67
WARRANTY REGISTRATION CARD	72

ABOUT THIS MANUAL

This engine installation and operation manual is provided as guidance for the installation of Hyundai SeasAll engine in a boat, and to describe engine operation. Its purpose is to provide technical information to aid in performing an effective engine installation so as to achieve both maximum performance and service life.

Hyundai SeasAll is committed to making clear and accurate information available for those who maintain, own and repair the L500 Series engines. Hyundai SeasAll values your input regarding revisions and additional information for our manuals.

- The manufacturer is not liable for any damages or losses caused by faulty installation, wrong handling of the equipment and/or deficient maintenance.
- The operator is responsible for the correct and safe operation of the engine and safety of its occupants and general public.
- It is strongly recommended that each operator read and understand this manual before installing and operating the engine.
- This manual as well as safety labels posted on the engine use the following safety alerts to draw your attention to special safety instructions that should be followed.
- Illustrations in this manual are subject to change without notice.



WARNING

DEVIATION FROM INSTALLATION INSTRUCTIONS AND OPERATION GUIDELINES MAY LEAD TO PERSONAL INJURY OR DEATH TO OPERATORS AND NEARBY PERSONNEL.



CAUTION

DEVIATION FROM INSTALLATION INSTRUCTIONS AND OPERATION GUIDELINES MAY LEAD TO IMPROPER OPERATION, DAMAGE OR DESTRUCTION OF THE ENGINE.

SAFETY PRECAUTIONS

- Read and understand this operator's manual as well as other information supplied by Hyundai SeasAll for safe use of these products. Be sure to check your engine regularly.
- Do not use the engine for a purpose other than what is intended by Hyundai SeasAll. Do not modify the performance of the supplied engine without the express permission of Hyundai SeasAll. This can be dangerous, can shorten the life of your engine and in-validate your warranty.
- Original and genuine parts supplied from Hyundai SeasAll must be used for inspections and maintenance. Hyundai SeasAll does not guarantee any damage caused by the use of imitation parts.
- Engine inspection and maintenance should be carried out by properly trained and factory approved service engineers.
- The engine should be inspected if the electronic engine control unit shuts down the engine.

HOT SURFACES AND FLUIDS

- There is always a risk of burns when working with a hot engine. Be aware of hot parts like the turbocharger system, the exhaust system, hot coolant hoses, etc. Wait until the engine is fully cool to do inspection and maintenance.

REFUELING

- Refuel only after the engine completely stops.
- Use only the recommended fuel. The wrong grade of fuel can cause operating problems, can cause the engine to stop and can cause engine damage.
- Pay special attention to safe practices when refueling.

PAINT DAMAGE

- Damage of the engine or parts paint during maintenance and inspection can cause corrosion. Any damage must be repainted after inspection and maintenance.

WELDING ON ENGINE

- Welding directly on the engine block can cause damage to the engine control systems. The ECU and related electronic devices must be disconnected and removed if unavoidable welding is needed.



ENGINE BREAK-IN

INITIAL BREAK-IN PROCEDURE

- The first 20 hours of operation is the engine break-in period. During this period, it is important that the engine is operated as outlined below.
- DO NOT operate engine at idle rpm for extended periods of time during the first 10 hours.
- DO NOT operate at any one constant speed for extended periods of time.
- DO NOT exceed 75% of full throttle during the first 10 hours except during the engine initial Break-In Procedure. During the next 10 hours, occasional operating at full throttle (5 minutes at a time maximum) is permissible.
- AVOID full throttle accelerations from neutral position.
- DO NOT operate at all full throttle until engine reaches normal operating temperature. (40 °C)
- FREQUENTLY CHECK engine oil level and add oil if necessary.

USING AND ASSEMBLING GENUINE PARTS

- Installation must be done and repairs must be performed using the special tools and procedures specified by Hyundai SeasAll.
- The limited warranty does not apply to any damage to our products caused by the installation or use of parts and accessories which are not manufactured or sold by us.
- Check for compliance with torque tightening requirements. (Contact your Hyundai SeasAll dealer or refer to the manual)
- Any gaskets, O-rings, seals or other sealing parts should be replaced with new parts during repairs.



WARNING

**DO NOT DRIVE IN SPACE WHERE THERE IS NO AIR CIRCULATION.
EMISSION GAS IS HARMFUL.**

APPROXIMATE CONVERSIONS FROM STANDARD							
	SYMBOL	MULTIPLY BY	SYMBOL		SYMBOL	MULTIPLY BY	SYMBOL
LENGTH	mm	0.039	inch	LENGTH	inch	25.4	mm
	cm	0.4	inch		inch	2.54	cm
	m	3.28	ft		ft	0.3048	m
AREA	mm ²	0.0016	in ²	AREA	in ²	645.2	mm ²
	m ²	10.764	ft ²		ft ²	0.093	m ²
VOLUME	cm ³	0.061	in ³	VOLUME	in ³	16.388	cm ³
	mL	0.06	in ³		in ³	16	mL
	Ldm ³	61.023	in ³		in ³	0.016	Ldm ³
	Ldm ³	0.22	imp.gallon		imp.gallon	4.545	Ldm ³
	Ldm ³	0.264	U.S.gallon		U.S.gallon	3.785	Ldm ³
	m ³	0.76	yd ³		yd ³	1.3	m ³
	m ³	35.315	ft ³		ft ³	0.028	m ³
FORCE	kgf	2.204	lbf	FORCE	lbf	0.453	kgf
	N	0.224	lbf		lbf	4.448	N
TEMP.	°F=9/5x°C+32			TEMP.	°C=5/9x(°F-32)		
PRESSURE	Bar	14.5	psi	PRESSURE	psi	0.068	Bar
	MPa	145	psi		psi	0.0068	MPa
	Pa	0.102	mmWc		mmWc	9.807	Pa
	Pa	0.004	inWc		inWc	249.098	Pa
	KPa	4	inWc		inWc	0.249	KPa
	mWg	39.37	inWc		inWc	0.025	mWg
TORQUE	Nm	0.738	lbf ft	TORQUE	lbf ft	1.356	Nm
WEIGHT	kg	2.205	lb	WEIGHT	lb	0.454	kg
	kg	35.273	oz		oz	0.028	kg
WORK	kJ/kWh	0.43	BTU/lb	WORK	BTU/lb	2.326	kJ/kWh
	MJ/kg	430	BTU/lb		BTU/lb	0.0023	MJ/kg
	kJ/kg	0.24	Kcal/kg		Kcal/kg	4.184	kJ/kg
ENERGY	kJ/kg	0.697	BTU/hph	ENERGY	BTU/hph	1.435	kJ/kg
FUEL CONSUMP.	g/kWh	0.736	g/hph	FUEL CONSUMP.	g/hph	1.36	g/kWh
	g/kWh	0.0016	lb/hph		lb/hph	616.78	g/kWh
FLOW RATE (GAS)	m ³ /h	0.588	ft ³ /min	FLOW RATE (GAS)	ft ³ /min	1.699	m ³ /h
FLOW RATE (LIQUID)	m ³ /h	4.403	US gal/min	FLOW RATE (LIQUID)	US gal/min	0.2271	m ³ /h
SPEED	m/s	3.281	ft/s	SPEED	ft/s	0.3048	m/s
	kph	0.539	knots		knots	1.852	kph
	mph	0.869	knots		knots	1.1508	mph
	kph	0.62	mph		mph	1.61	kph

CHAPTER 1
ENGINE OVERVIEW

ENGINE COMPONENTS

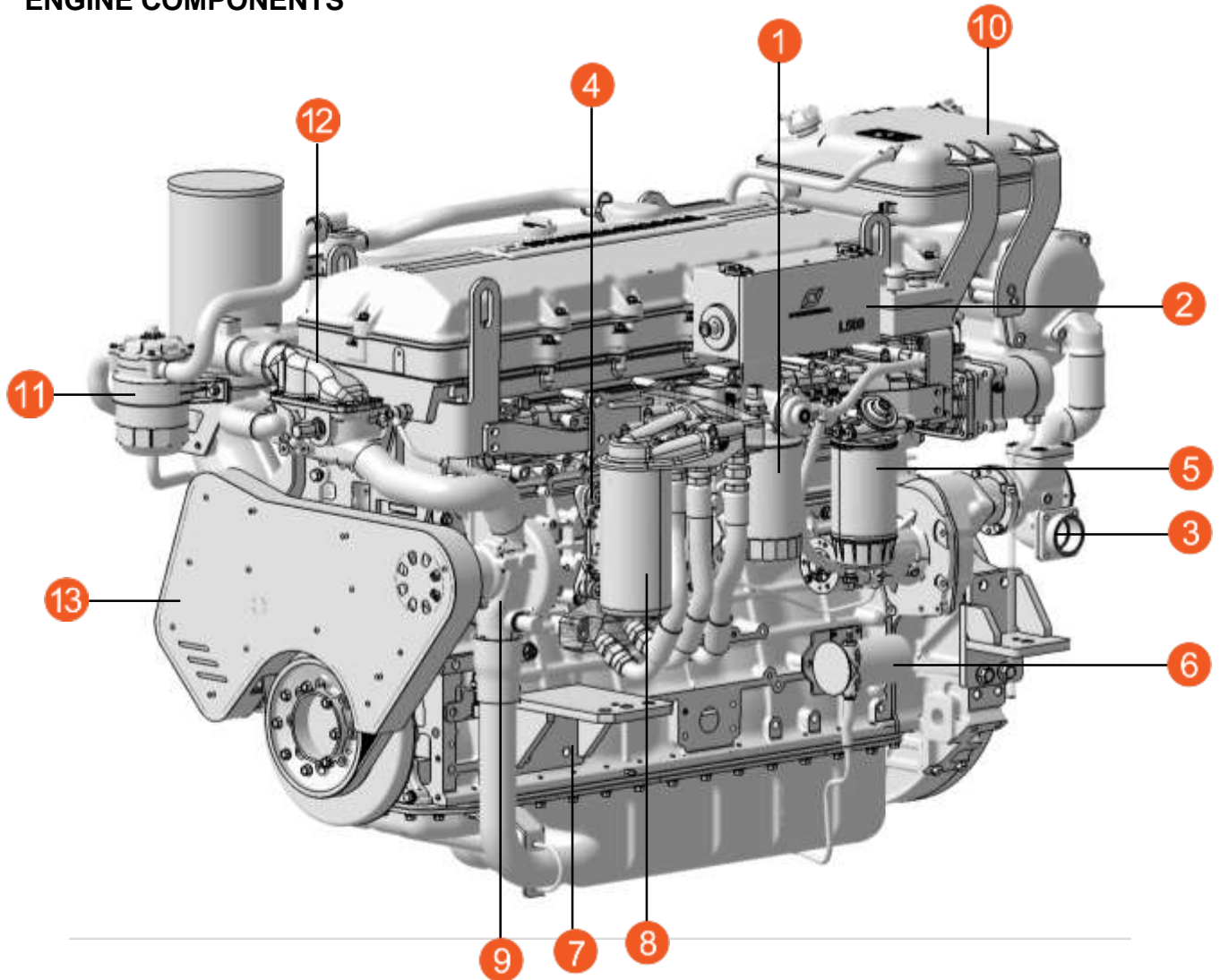

- | | |
|----------------------------|-----------------------|
| ① FUEL FILTER | ⑧ OIL FILTER |
| ② JUNCTION BOX | ⑨ WATER PUMP |
| ③ SEAWATER PUMP | ⑩ EXPANSION TANK |
| ④ ECU | ⑪ CCV FILTER |
| ⑤ WATER SEPARATOR | ⑫ THERMOSTAT |
| ⑥ OIL EXTRACTION PUMP | ⑬ BELT COVER (OPTION) |
| ⑦ ENGINE MOUNTING BRACKETS | |

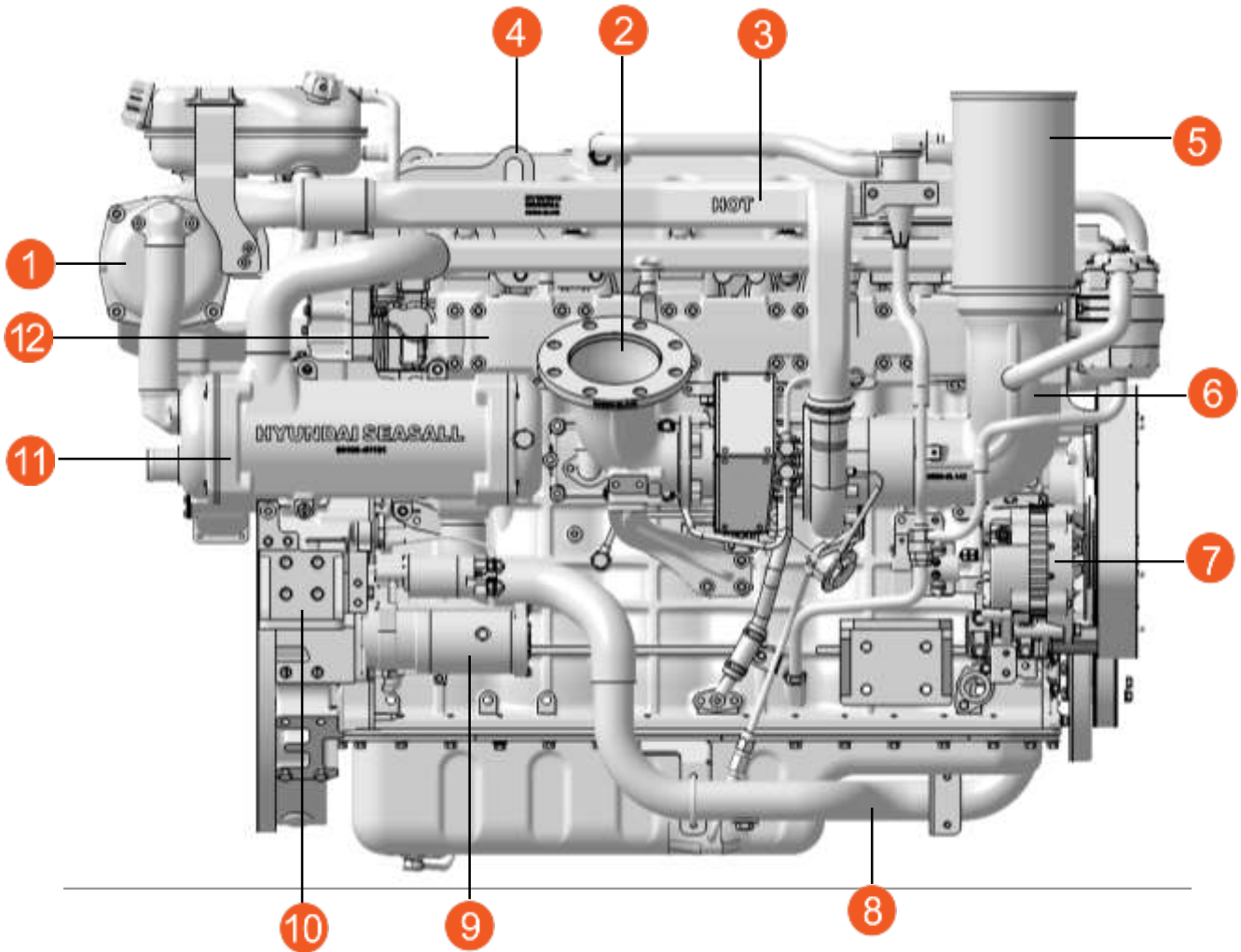

- | | |
|-----------------------------|--|
| ① INTERCOOLER | ⑧ COOLANT PIPE (HEAT EXCHANGER OUTLET) |
| ② DRY EXHAUST PIPE | ⑨ STARTER MOTOR |
| ③ TURBO-CHARGER OUTLET PIPE | ⑩ ENGINE MOUNTING BRACKET |
| ④ LIFTING EYES | ⑪ HEAT EXCHANGER |
| ⑤ AIR FILTER | ⑫ EXHAUST MANIFOLD |
| ⑥ AIR FILTER CONNECTOR | |
| ⑦ ALTERNATOR | |

TECHNICAL DATA

	L500	L600	L700	L13G			
Engine type	4-stroke, 4-valve						
	After-cooled, Electronic Unit Injector (EUI), Turbocharger						
Output ps (kW)	500PS (368kW)	600PS (441kW)	700PS (515kW)	460PS (338kW)	500PS (368kW)	415PS (305kW)	450PS (331kW)
rpm at full load	1,800 rpm	2,000 rpm	2,300rpm	1,500rpm	1,800rpm	1,500rpm	1,800rpm
Cylinders	I-6						
Ignition sequence	1-5-3-6-2-4						
Displacement [cm ³]	12,736						
Bore [mm]	130						
Stroke [mm]	160						
Compression ratio	16.0 : 1						
Max. torque [kg.m] @ speed [rpm]	232		245	-			
	1,200		1,200	-			
Injection system	EUI						
Diesel fuel	at least CN 51 as per DIN EN 590						
Intake air pressure (abs. bar) @ speed [rpm]	2.7						
	1,800						
Coolant quantity (liter)	52						
Coolant cap opening pressure (bar)	0.7						
Engine oil (liter)	42						
Engine oil pressure (bar)	2.7 (600rpm), 4(1,800rpm), 4(2,000rpm) [100°C(oil temp.)]						
Exhaust gas pressure (kPa)	10						
Alternator [A]	90						
Engine diagnosis	Yes						
Weight (kg)	1,310		1,320	1,310			
Battery capacity (AH)	24V, 100AH						
Thermostat opening temp. (°C)	71 (starting to open), 83 (fully open)						
Idle rpm warmed up (rev/min)	600 (500~800 rpm idle control is possible) (But from 500~600 rpm G-SCAN is required)						
Permissible engine oil temp (°C)	135						
Permissible engine coolant temp (°C)	105						
Fuel Efficiency(L/h)	89.2	116.4	143.4	76.6	89.2	68.9	80.3

PERFORMANCE CURVES

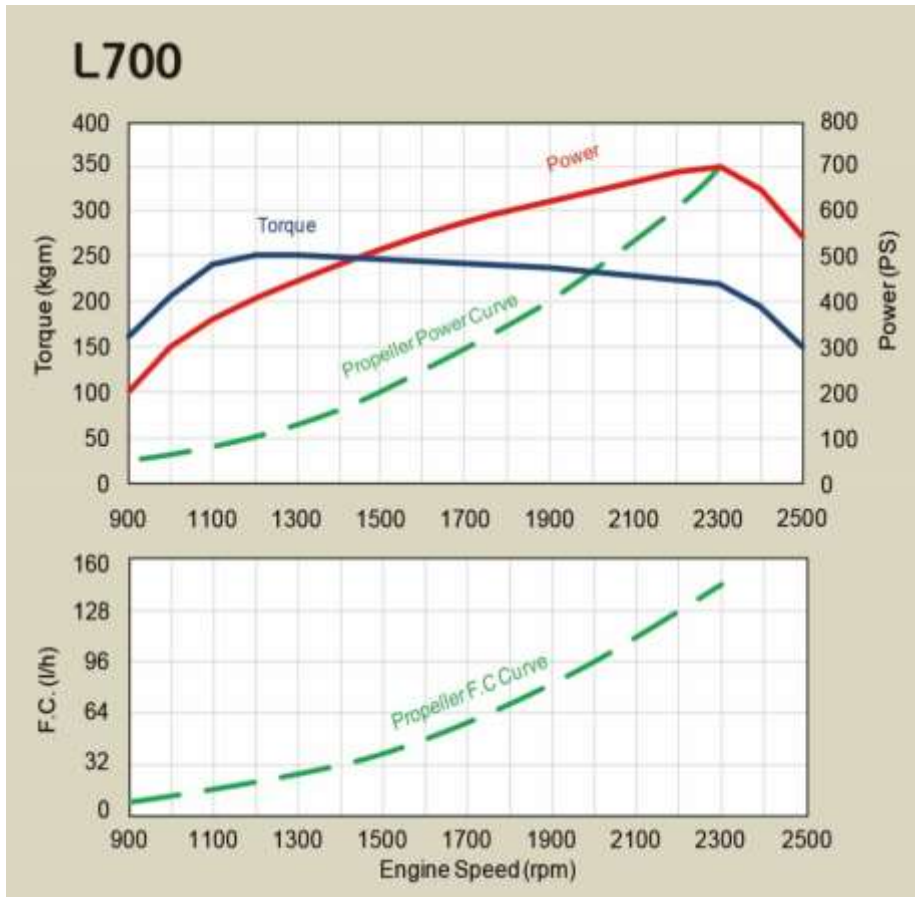
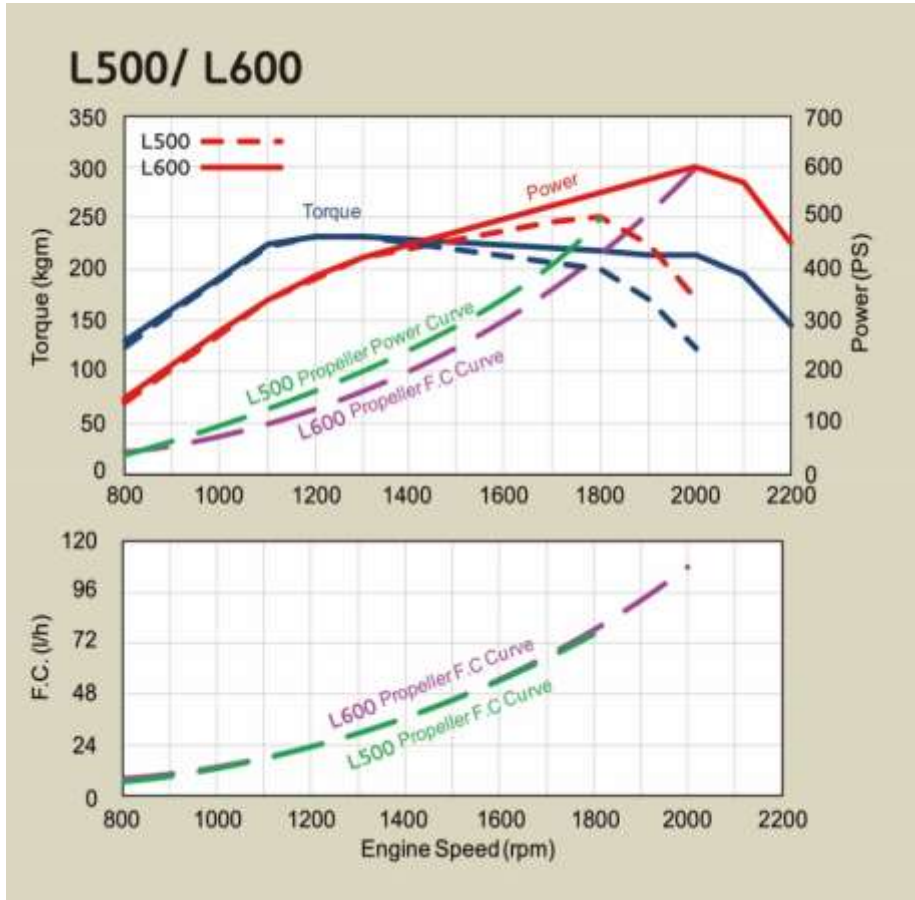

ENGINE IDENTIFICATION

Engine identification is affixed to the engine block . (See figure).

• **SERIAL NUMBER ON THE ENGINE BLOCK**

FORMAT : **D6CE**XXXXXX



• **ENGINE NAME PLATE**

HYUNDAI SEASALL	
Hyundai SeasAll co., Ltd.	
Engine Family	D6CE
Engine Type	L500
Engine Serial No.	XXXXXXXX
Rated Power @Speed	500PS @ 1800rpm
No. Of Cylinder	6
Bore x Stroke	130 x 160
Manufacture Date	MM/YYYY

HYUNDAI SEASALL	
Hyundai SeasAll co., Ltd.	
Engine Family	D6CE
Engine Type	L600
Engine Serial No.	XXXXXXXX
Rated Power @Speed	600PS @ 2000rpm
No. Of Cylinder	6
Bore x Stroke	130 x 160
Manufacture Date	MM/YYYY

HYUNDAI SEASALL	
Hyundai SeasAll co., Ltd.	
Engine Family	D6CE
Engine Type	L700
Engine Serial No.	XXXXXXXX
Rated Power @Speed	700PS @ 2300rpm
No. Of Cylinder	6
Bore x Stroke	130 x 160
Manufacture Date	MM/YYYY

HYUNDAI SEASALL			
EMISSION CONTROL INFORMATION			
EPA Engine Family	KHYSN12.7HYS	IMO Engine Family	KHYSN12.7HYS
Max Power	441 (kW)	Power Density	34.6 (kW/L)
Displacement / Cylinder	2.12(L/cyl)	Manufacture Date	MM/YYYY
Application	Commercial	Useful Life	10,000 hours or 10 years
Emission Standard	THC+NOx : 5.6 (g/kWh)	PM : 0.10 (g/kWh)	CO : 5.0 (g/kWh)
EMISSION CONTROL SYSTEM			
THIS ENGINE IS EQUIPPED WITH ELECTRONIC DIRECT FUEL INJECTION SYSTEM.			
THIS ENGINE IS CERTIFIED TO OPERATE ON DIESEL			
THIS MARINE ENGINE COMPLIES WITH U.S. EPA REGULATION FOR 2019			

HYUNDAI SEASALL			
EMISSION CONTROL INFORMATION			
EPA Engine Family	KHYSN12.7HY2	IMO Engine Family	KHYSN12.7HY2
Max Power	515 (kW)	Power Density	40.4 (kW/L)
Displacement / Cylinder	2.12(L/cyl)	Manufacture Date	MM/YYYY
Application	Commercial	Useful Life	10,000 hours or 10 years
Emission Standard	THC+NOx : 5.8 (g/kWh)	PM : 0.12 (g/kWh)	CO : 5.0 (g/kWh)
EMISSION CONTROL SYSTEM			
THIS ENGINE IS EQUIPPED WITH ELECTRONIC DIRECT FUEL INJECTION SYSTEM.			
THIS ENGINE IS CERTIFIED TO OPERATE ON DIESEL			
THIS MARINE ENGINE COMPLIES WITH U.S. EPA REGULATION FOR 2019			

EPA

ENGINE HANGER

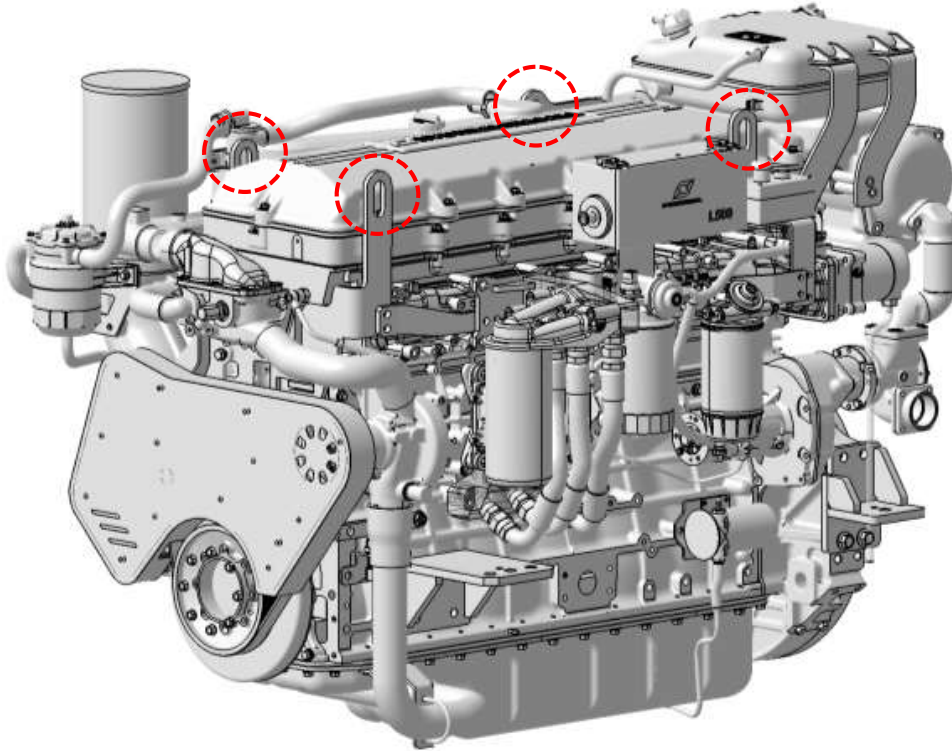

- To lift the engine, use the four lifting eyes (see illustration).
- To avoid engine damage, take care that engine lifting chains or belts do not hit or touch surrounding parts during engine lifting.
- Keep the engine horizontal when you install or remove the engine from the engine room by using correct installation tools or adjusting the length of lifting belts or chains.
- Use strong enough lifting belts or chains to carry the engine weight safely.

ENGINE DIMENSIONS

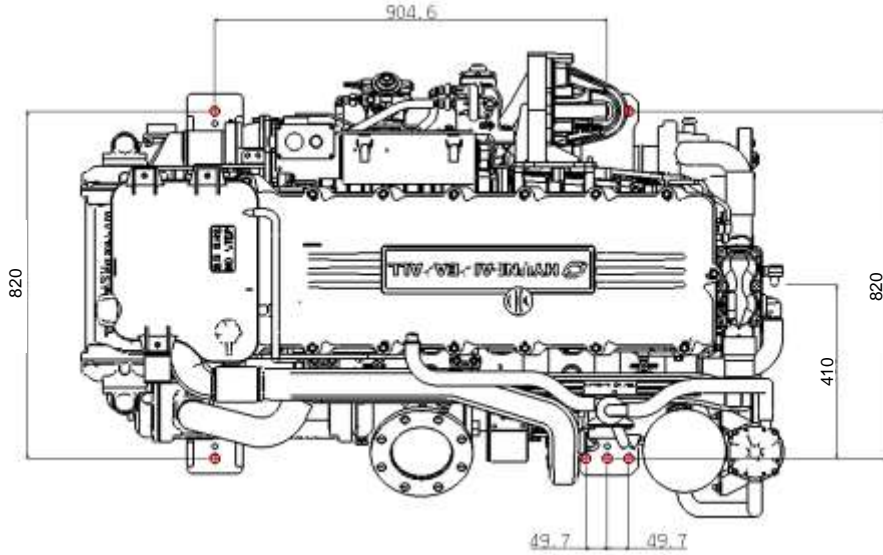

Top

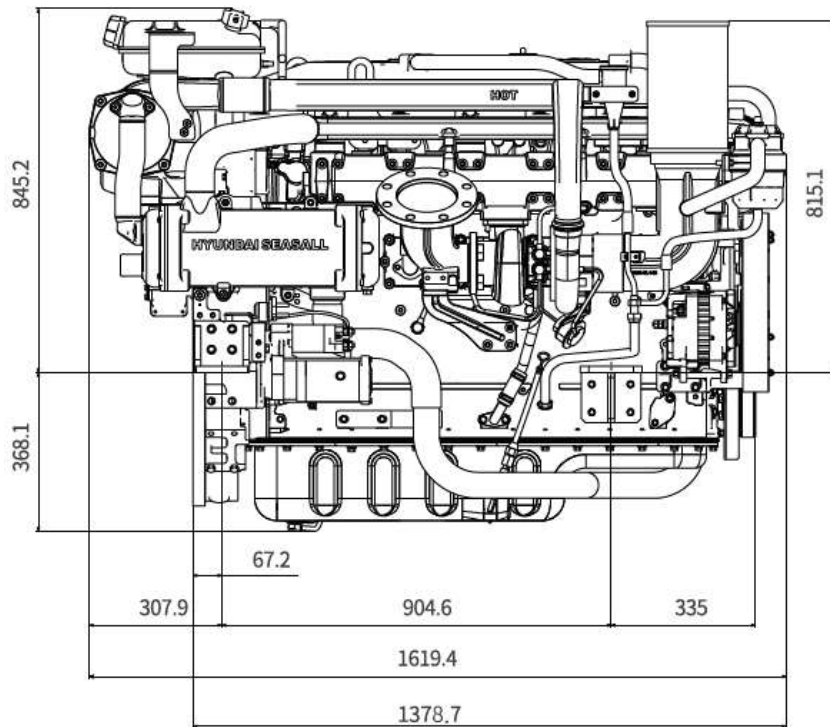

Side

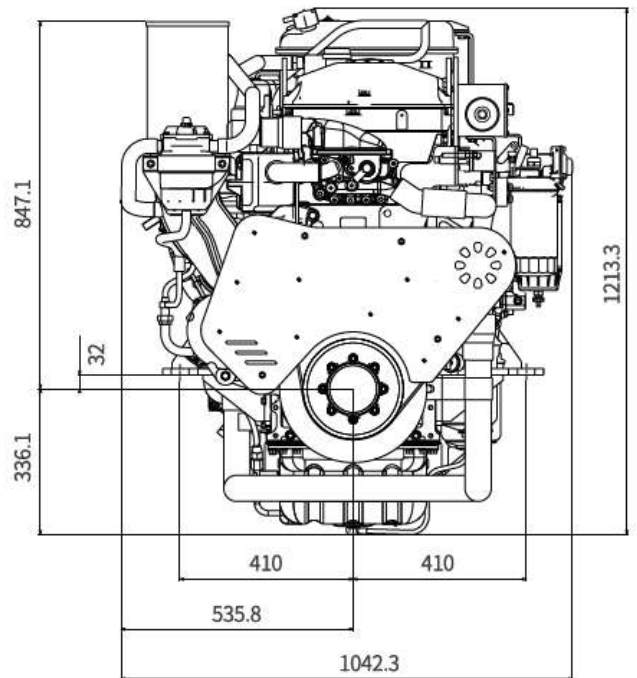

Front

PTO PULLEY REFER DRAWING

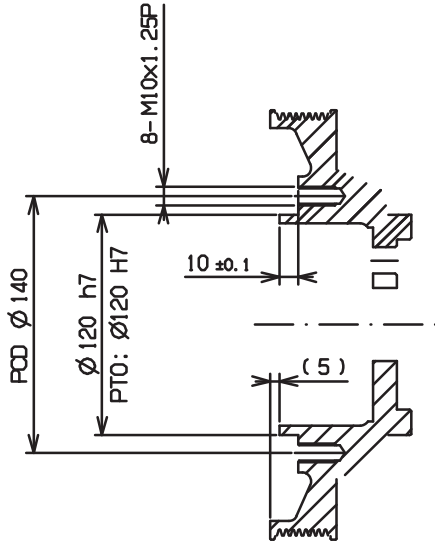

Section cut A-A
Scale:1:1

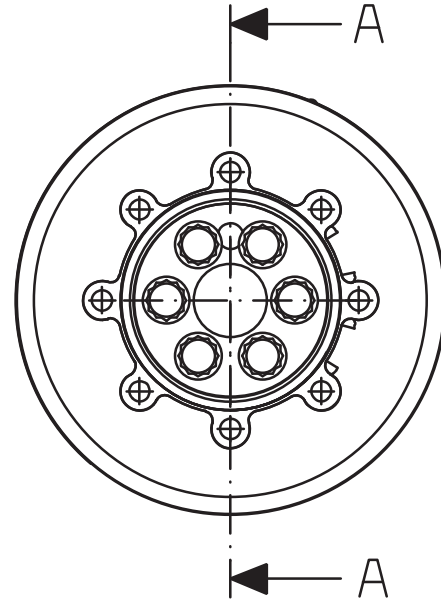

<CRANK PULLEY >

T/M ASSEMBLY BOLT PATTERN

- BELL HOUSING : SAE 1
- FLYWHEEL : SAE 14

BELT INSTALLATION

MODEL : L13	
AN	ALTERNATOR
DP	DRIVE PULLEY
IP	IDLER PULLEY
TP	TENSIONER PULLEY
WP	WATER PUMP PULLEY

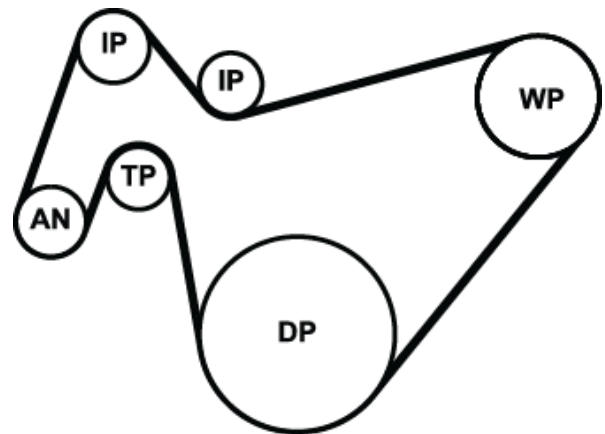

CHAPTER 2 ENGINE OPERATION

STARTING ENGINE

- Before starting the engine, you should check engine oil, coolant, gearbox oil, fuel gauge, seawater pump, battery, water valves etc.
- When you start the engine, check that the engine throttle lever ① is in the neutral position. If not, the engine may not start or there is possibility of the boat moving inadvertently. If your boat is equipped with a neutral safety switch, the engine will only crank when the engine throttle lever is in the neutral position.
- After starting the engine, release the key ② immediately to prevent damage to the starter motor.
- Avoid maximum rpm and WOT (Wide Open Throttle) before the cold engine is fully warmed up(40°C).
- When cold starting, it may take a few more seconds to start the engine.
- If the engine does not start in 10 seconds, turn off the key and wait. After 10 seconds try again. This method can help avoid starter motor damage.

- The engine room requires a constant supply of fresh air.
- Be sure that adequate ventilation systems are installed.

STOPPING ENGINE

- The engine should be run for a few minutes at idle (in neutral) before turning it off. This will avoid boiling the coolant and will even out the temperature. This is especially important if the engine has been operated at high engine speeds and loads.
- Never switch off the main switches while the engine is running. This could damage some parts such as the alternator.

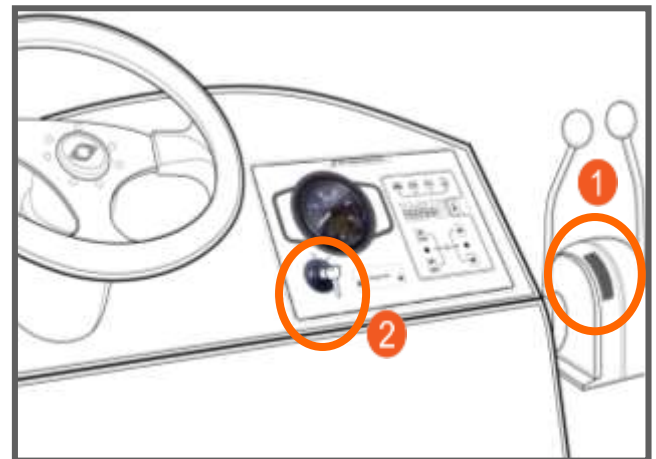

WARNING

DO NOT DRIVE IN SPACE WHERE THERE IS NO AIR CIRCULATION.
EMISSION GAS IS HARMFUL.

EMERGENCY STOP

- You can stop the engine by pushing this button. After releasing the switch by twisting the button, you can start the engine again. (Normally, the button should be in the 'out' position.)
- When the switch is pressed or it doesn't work normally, the engine doesn't crank.
- We recommend that you check this switch first if there is any cranking problem.
- You can use this switch to avoid unexpected engine starting during maintenance.
- You can use this switch in any emergency situation.

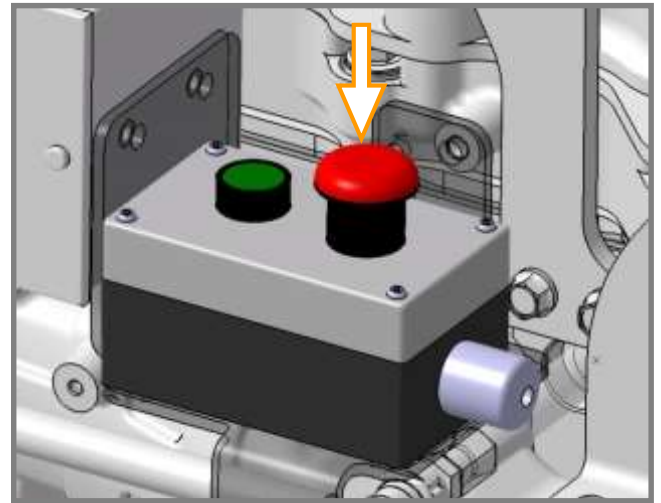

Emergency Stop Switch

INTAKE AIR HEATER

- When turning the start switch ON, the coolant temperature sensor senses the engine coolant temperature and the control unit (ECU) controls the preheating time in accordance with the sensed coolant temperature.
- When the engine is started, the control unit (ECU) operates the air heater for a certain time. This preheats the engine and helps to reduce white smoke at start-up.
- If the indicator lamp blinks regardless of condition, check the related circuit for a blown fuse, fused relay etc. since this indicates a problem in the preheating heater system.

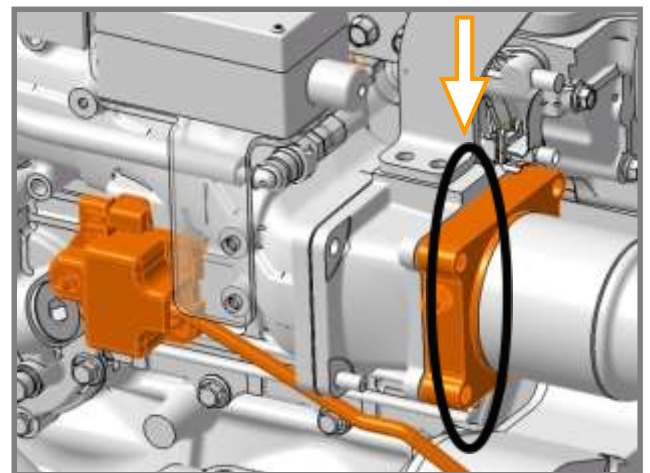

Air Heater

CHAPTER 3
COOLING SYSTEM

SCHMATIC DIAGRAM OF ENGINE COOLING CIRCUIT

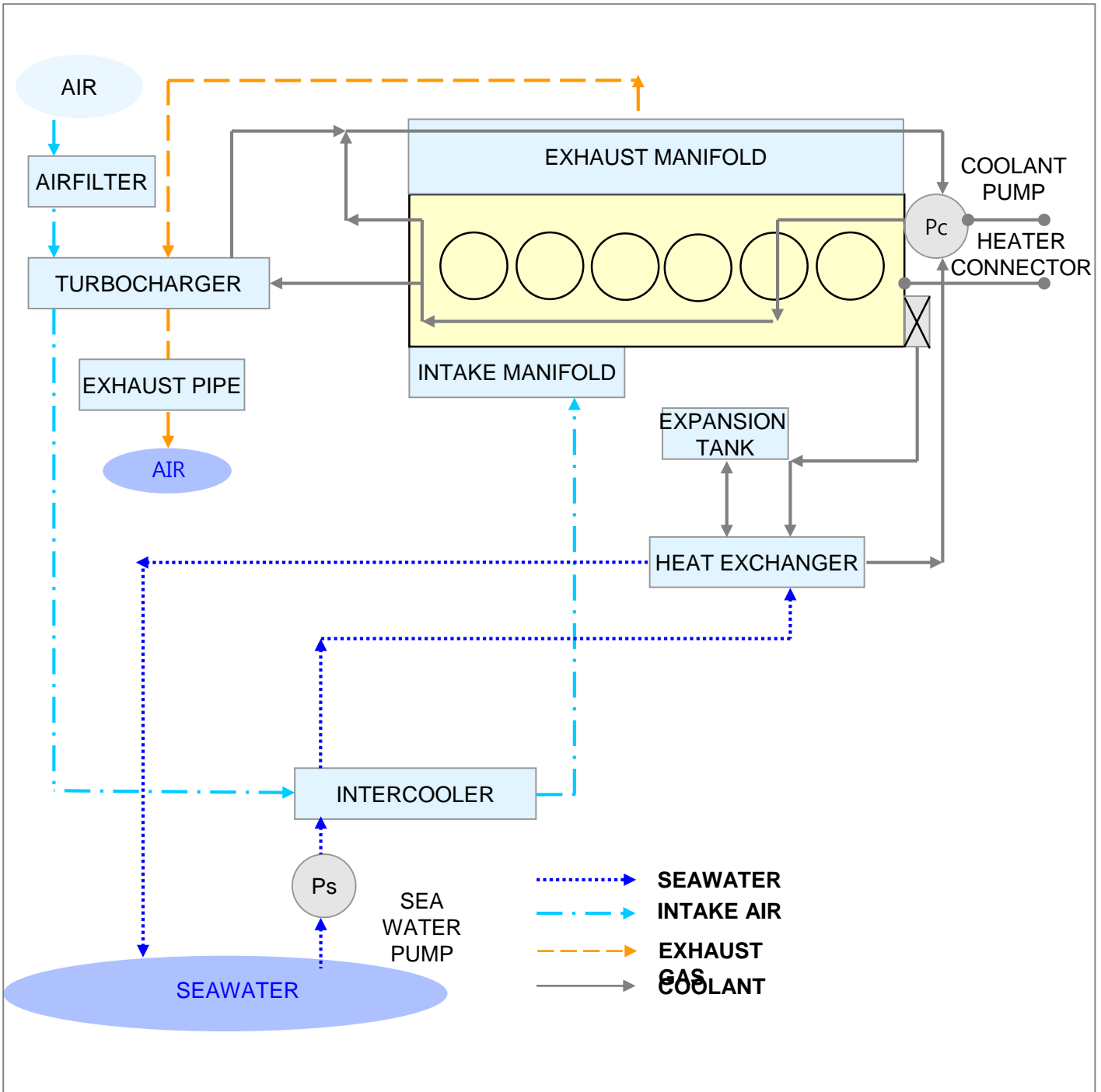

SEAWATER FLOW – OPENED COOLING CIRCUIT

Water strainer ← Water valve ← Water pickup

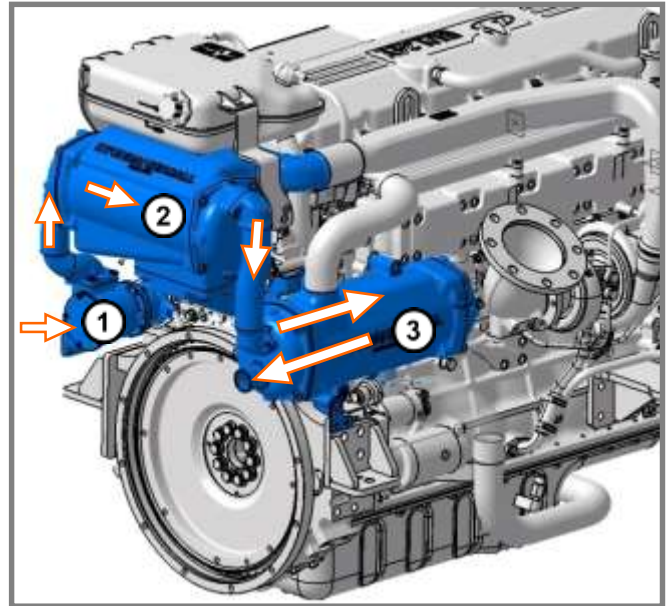
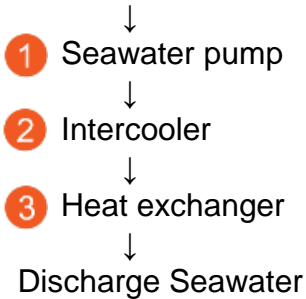

WATER PICKUP

- Water pickup should be installed in an area where it won't pick up air bubbles and will access clean water during all phases of the engine operation.
- After start up, you must check for air bubbles by inspecting the waterline. Bubbles will appear if there is a leakage from the waterline. If bubbles appear, leakage area must be detected and completely sealed prior to engine operation.
- The seawater pickup inner diameter, as well as all other connecting fittings (hoses, connectors, water valve etc.) must be at least the size of the inner diameter of the inlet of the seawater pump. If not, it may inhibit the supply of sufficient water and cause the engine to overheat.

WATER STRAINER

- Strainer should be located in an area where it will be easily accessible for periodic seawater flow inspection and cleaning.
- The size of strainer must be of sufficient capacity to pass the seawater (a flow rate over 400 liters per minute).
- Strainer must be installed after water inlet valve in order to allow user to shut off seawater when cleaning strainer filter.

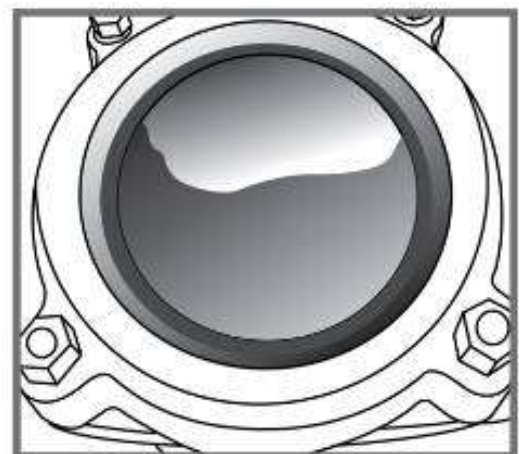

CAUTION
 IF THE SEAWATER STRAINER IS NOT PROPERLY ASSEMBLED, AIR CAN BE SUCKED INTO THE COOLING CIRCUIT, DISTURBING THE VACUUM PROCESS. THIS CAN CAUSE THE ENGINE TO OVERHEAT.

CLEANING STRAINER FILTER

- Stop the engine and close the water valve.
- Remove the filter cap.
- Remove the filter element, flush it thoroughly with clean water or compressed air.
- Insert the cleaned filter element and screw on the filter cap.
- Check the cap and the gasket for correct seating and sealing.
- Open the water valve.
- Start the engine and check if there is water leakage.



AUTOMATIC DRAIN VALVE

- The Automatic Drain Valve allows condensed water in the intercooler to drain when the engine is a idle or is stopped.

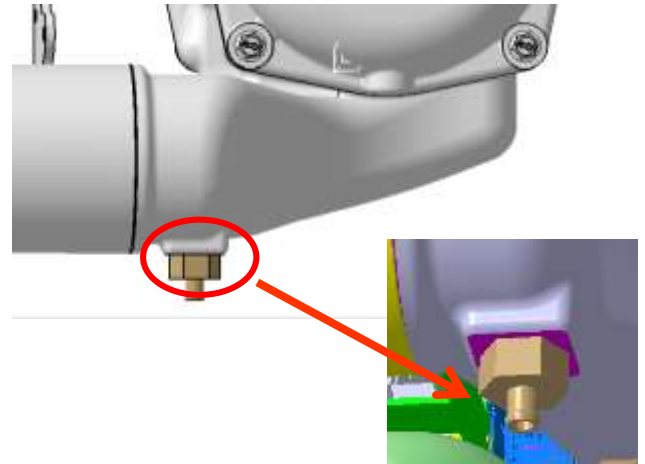

Condensate water drain from intercooler.

CHECKING AUTOMATIC DRAIN VALVE

- Stop the engine and remove the Automatic Drain Valve from the intercooler.
- Removing procedure:
 - Remove the Snap Ring ①
 - Remove the Plunger ②
 - Remove the Spring ③
 - Clean the inside of the Automatic Drain Valve with a cloth or by brushing
- Installation is in the reverse order of removal.
- Put the Automatic Drain Valve on a flat surface. Make sure that Snap Ring ① and plunger ② are in contact.
- If there is more than a 2mm gap between the Snap Ring ①, and the Plunger ② replace the spring.

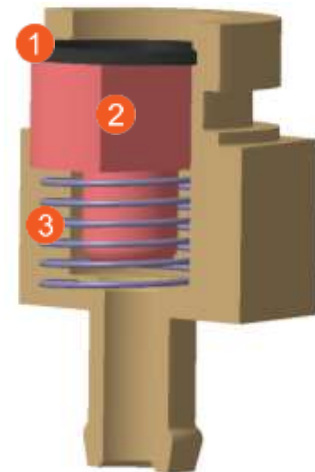

① Snap-Ring ② Flanger ③ Spring

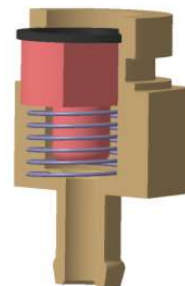

Normal



Replace a part

SEAWATER PUMP

- The internal diameter of hose connected to seawater pump inlet should be PF 2 Inch.
- The cross section of the hose may shrink due to inlet pressure drop. Therefore, the hose from water pickup in the boat's hull to the seawater pump inlet should be as short as possible and must be made of steel wire reinforced material.
- The seawater pump impeller must be checked periodically and replaced if necessary.

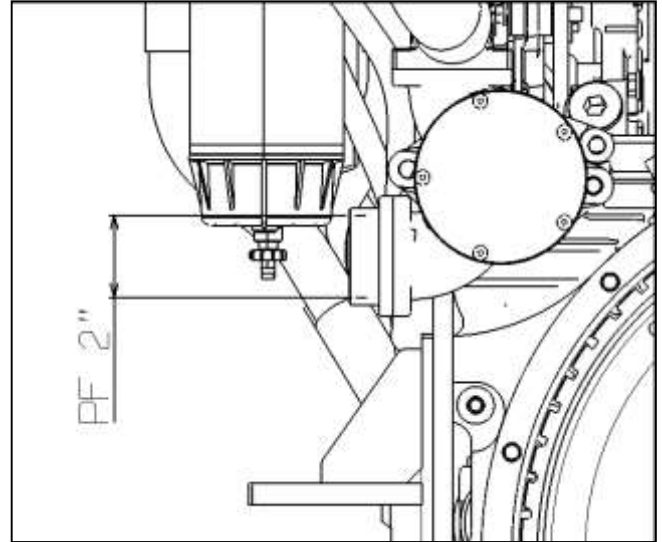

CAUTION

IF THE WATERPUMP IS NOT PROPERLY ASSEMBLED, AIR CAN BE SUCKED INTO THE COOLING CIRCUIT, DISTURBING THE VACUUM PROCESS. THIS CAN CAUSE THE ENGINE TO OVERHEAT.



CAUTION

DO NOT RUN THE ENGINE WITHOUT SEAWATER. THE SEAWATER PUMP IMPELLER WILL BE DAMAGED. BEFORE STARTING THE ENGINE, BE SURE TO SUPPLY SEAWATER TO THE PASSAGES.



CAUTION

DO NOT INSTALL ADDITIONAL DEVICES WHICH COULD OBSTRUCT THE FLOW OF SEAWATER. THIS CAN CAUSE THE ENGINE TO OVERHEAT.

CHECKING SEAWATER PUMP & IMPELLER

- Stop the engine and close the water valve.
- Remove the impeller housing cover.
- Remove the impeller from inside the seawater pump.
- Check the condition of impeller and bushing.
- Apply soapy water to impeller when assembling, and reassemble towards rotation direction.
- Replace the O-ring on the impeller housing cover.
- Open the water valve.
- Start the engine and check if there is water leakage.



CAUTION

DO NOT RUN THE ENGINE WITHOUT SEAWATER. THE SEAWATER PUMP IMPELLER WILL BE DAMAGED. BEFORE STARTING THE ENGINE, BE SURE TO SUPPLY SEAWATER TO THE PASSAGES.



CAUTION

IMPELLER DAMAGE MAY OCCUR IF APPROPRIATE TOOLS ARE NOT USED WHEN REMOVING THE IMPELLER. MAKE SURE TO CHECK O-RING CONDITION AFTER SEAWATER PUMP REASSEMBLY.



CAUTION

DO NOT INSTALL ADDITIONAL DEVICES WHICH COULD OBSTRUCT THE FLOW OF SEAWATER. THIS CAN CAUSE THE ENGINE TO OVERHEAT.

ENGINE COOLANT FLOW – CLOSED COOLING CIRCUIT

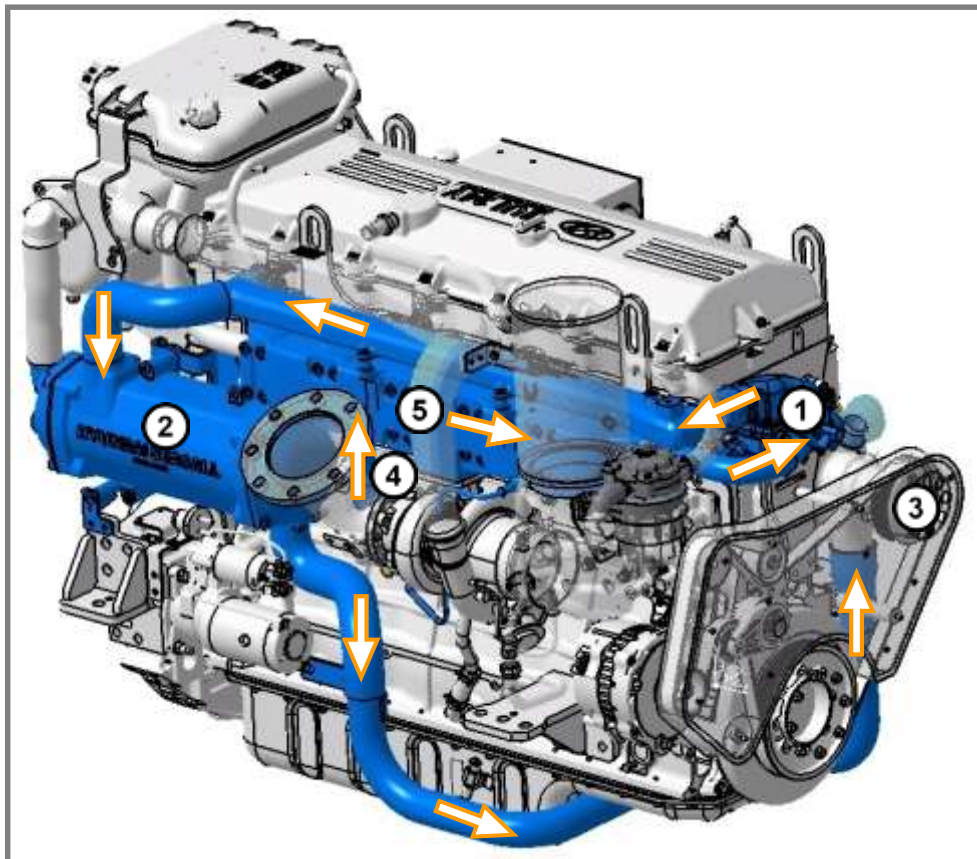
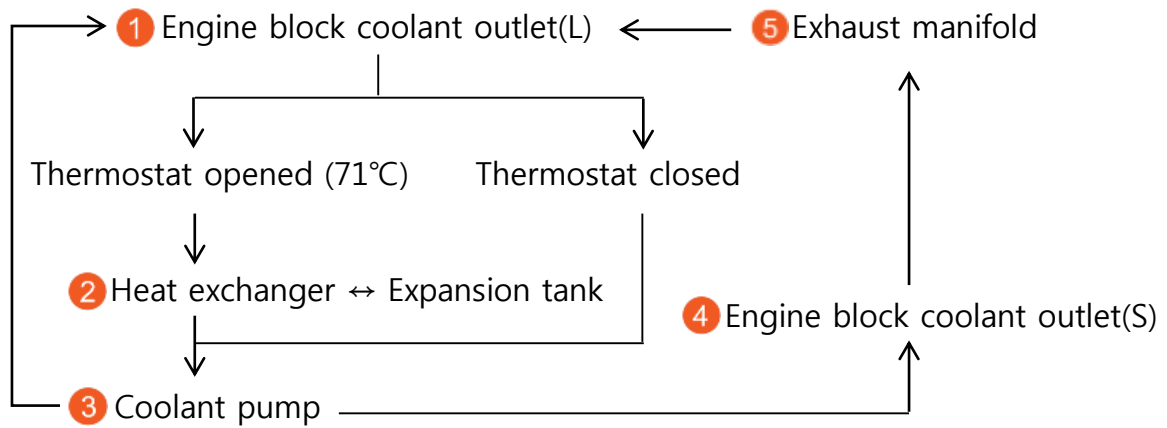

ENGINE COOLANT

- Engine coolant must be maintained at the “MIN” level marked on the side of the expansion tank when the engine is cold.
- As the engine temperature increases, the pressure inside the cooling system increases to 0.7 bar or more. To maintain proper pressure of the engine cooling system, water may be ejected from the expansion tank. This is normal. Replenish the coolant if this is observed.

SUPPLEMENTAL ENGINE COOLANT

- If the coolant level is below level 'Low', add enough specified coolant to provide protection against freezing and corrosion. Coolant level should be between the MAX and MIN. But do not exceed level 'MAX'.
- If frequent additions are required, contact an authorized dealer for a cooling system inspection.
- Use only soft (demineralized) water in the coolant mixture.
- The engine has aluminum engine parts and must be protected by an ethylene-glycol-based coolant to prevent corrosion and freezing.
- DO NOT USE alcohol or methanol coolant or mix them with the specified coolant.
- DO NOT USE a solution that contains more than 60% antifreeze or less than 35% antifreeze, which would reduce the effectiveness of the solution. For mixture percentages, refer to the table.

Ambient Temperature	Mixture Percentage(volume)	
	Antifreeze	Water
-15°C (5°F)	35	65
-25°C (-13°F)	40	60
-35°C (-31°F)	50	50
-45°C (-49°F)	60	40

DRAINING COOLANT

- In order to drain engine coolant, please use a screwdriver to loosen the drain plug ①.
- The drain plug is located under the heat exchanger unit.

Heat Exchanger

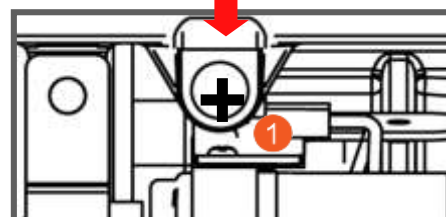
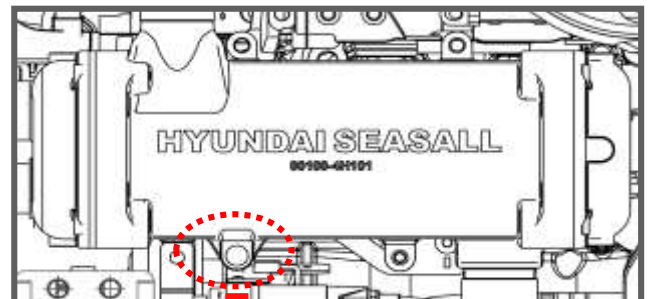

Drain Plug

REMOVING AIR BUBBLES IN COOLANT

- Start the engine and warm it up at a low rpm.
- Stop the engine and allow the engine to cool, then open the cap of the expansion tank carefully.

*NOTE: Never open the cap when the engine is hot. It may cause scalding.

- Refill with coolant if needed.
- Reinstall the expansion tank cap.
- Check the level of the expansion tank regularly.

CABIN HEATER CONNECTION

- In order to use a cabin heater, an extra coolant circulation pump is needed.
- After connecting cabin heater lines, engine coolant must be refilled and checked.
- Check coolant flow direction, as shown in the figure.
- If a cabin heater is installed, the volume of the cooling circuit will be increased. It may be necessary to add an additional expansion tank to avoid losing cooling water as the expansion tank on the engine may not have sufficient capacity.
- Contact your Hyundai SeasAll dealer if you need nipples for cabin heater connection.

Coolant flow direction: 

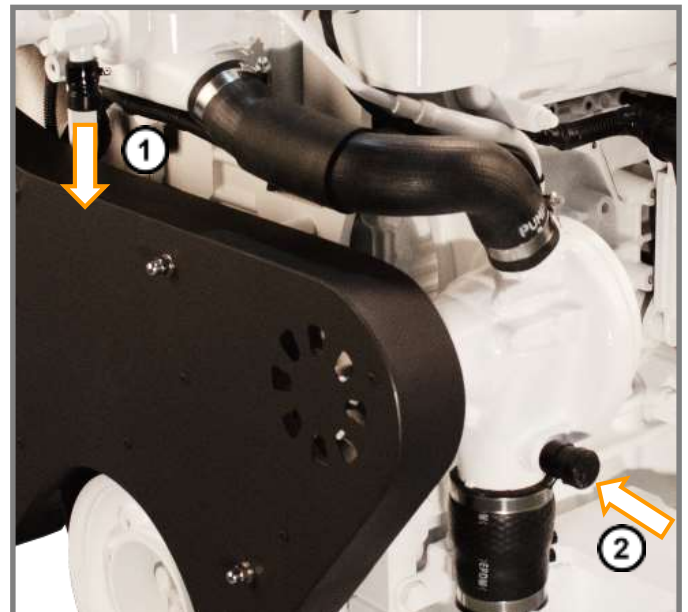

① To heater

※HOSE INNER DIAMETER Φ 17

② From heater



WARNING

NEVER OPEN THE EXPANSION TANK CAP WHEN THE ENGINE IS OPERATING OR HOT. IT COULD RESULT IN SERIOUS PERSONAL INJURY AND MAY CAUSE ENGINE DAMAGE.

CHAPTER 4 FUEL SYSTEM

The unit injector consists of a pumping element (A), a controlling component (B), and a nozzle (C) as shown in the illustration. The pumping element (A) generates the fuel pressure as the force from the cam drives the plunger via the rocker arm. The controlling component (B) controls the operation of the spill valve and needle control valve by driving the solenoid according to the commands from the ECU. Finally the nozzle element (C) injects the pressurized fuel into the cylinder

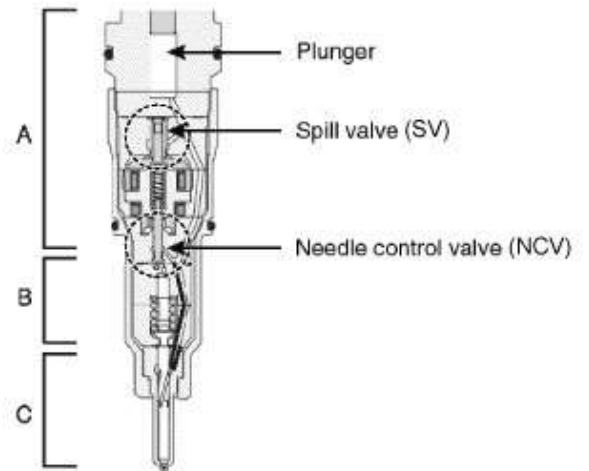

EUI SYSTEM

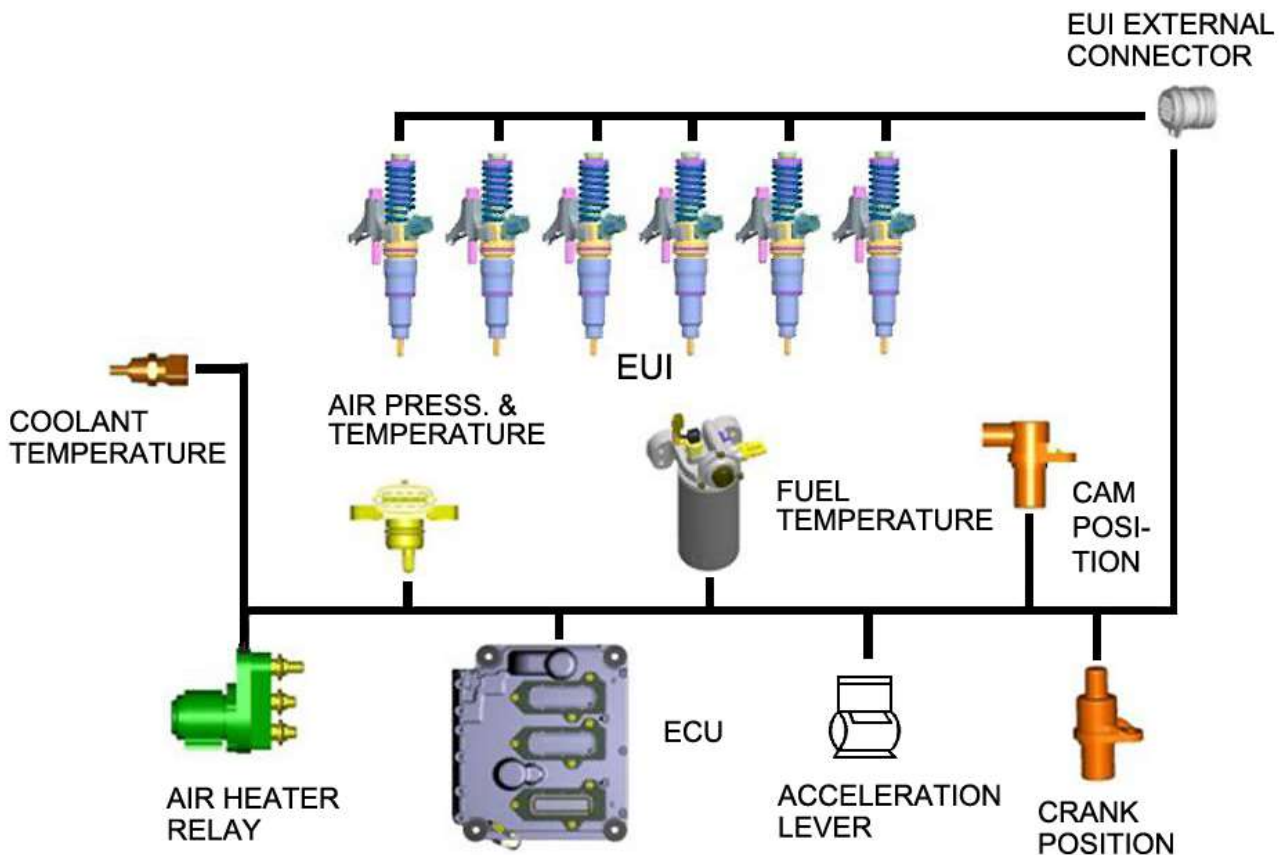

FUEL SUPPLY SYSTEM

- The fuel system consists of an electronic control unit (ECU), unit injectors, a fuel pump, fuel lines, a fuel filter, an overflow valve, a fuel tank etc.
- Fuel from the fuel filter is supplied into the fuel gallery in the cylinder head. After fuel is injected by six unit injectors it passes through the overflow valve installed at the exit of the fuel gallery. Fuel returned from the cylinder head goes back into the fuel tank.
- Accordingly, the fuel system continues to supply the proper amount of fuel required by the engine as determined by the control unit (ECU).
- The fuel supplied from the fuel pump to the engine is injected by the injector, the remaining fuel returns to the fuel tank.

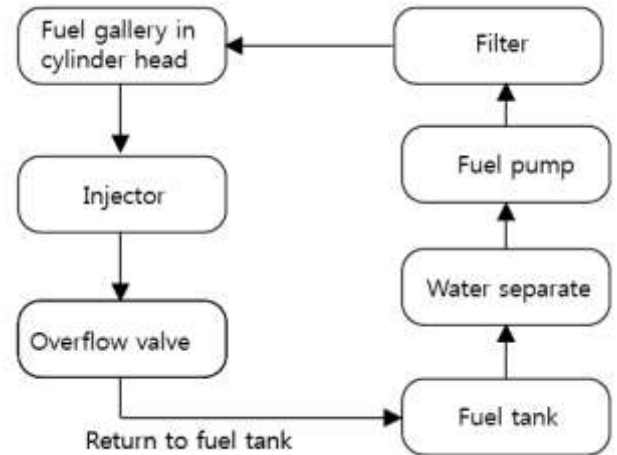

FUEL LINE

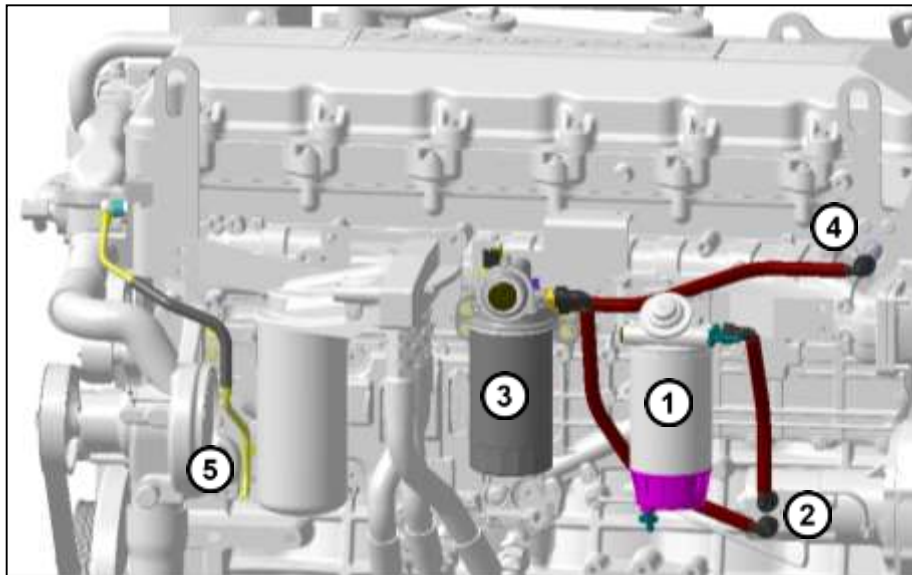

- ① From fuel tank to separator
- ② From separator to fuel pump
- ③ From fuel pump to fuel filter
- ④ From fuel filter to fuel gallery
- ⑤ From fuel gallery to fuel tank

※ The minimum inner diameter of the fuel hoses should be at least Ø10

RECOMMENDED FUEL QUALITY

The following fuels should be used for engine operation:

- Standard summer / winter diesel fuel according to DIN EN 590 (classes A-F)
- Diesel fuel according to DIN EN 590 (classes 0-4) in arctic climates
- Summer diesel fuel according to California and U.S. federal regulations
- Winter diesel fuel if lubricity is comparable to diesel fuel according to DIN EN 590
- Mixture of diesel fuel with 5 Vol.% RME according to DIN 51606
- Other admixing or additional use of additives, gasoline or special fuels is not permitted

DRAINING WATER FROM FUEL FILTER

- The water separator for a diesel engine plays the important role of separating water from fuel and accumulating the water in its base.
- If your fuel is not well suited to your engine, more frequent drainage will be required.
- To check and drain the water in fuel filter:
 - 1) Loosen the drain plug ① and drain water.
 - 2) After water is drained, securely tighten the drain plug.

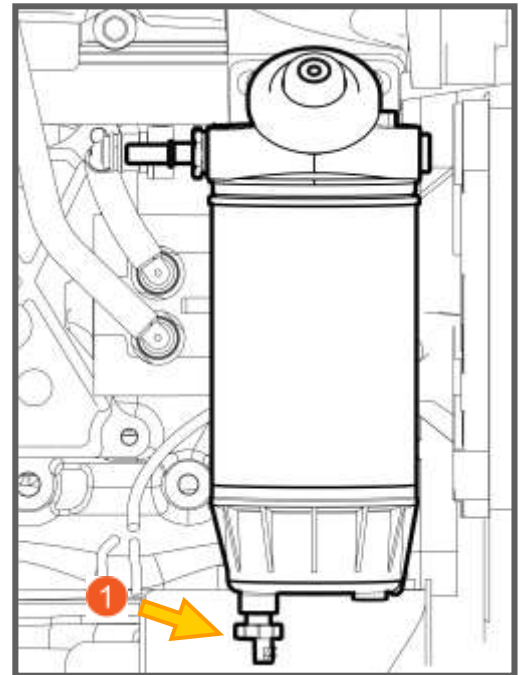

CAUTION

HYUNDAI SEASALL'S GUARANTEES OR WARRANTIES ARE VOID IN CASES WHERE DAMAGE TO FUEL INJECTION COMPONENTS (HIGH PRESSURE PUMP, INJECTORS, ETC.) CAN BE ATTRIBUTED TO THE USE OF UNQUALIFIED FUELS.

IF WATER ACCUMULATED IN THE FUEL FILTER IS NOT DRAINED AT PROPER TIMES, DAMAGE TO MAJOR ENGINE PARTS MAY OCCUR. WHEN REPLACING THE FUEL FILTER CARTRIDGE, USE ONLY GENUINE HYUNDAI SEASALL PARTS.

CHANGING FUEL FILTER

When replacing a fuel filter element

- Clean around the fuel filter.
- Loosen air vent bolt 'A' on fuel filter and relieve the pressure in the fuel line.
- Replace the filter element.

(Replacement of the filter cartridge)

- 1) Check if there is any gasket on the cartridge when replacing it.
- 2) Apply oil to gasket and tighten it sufficiently by hand.
- 3) Tightening torque regulation : $43.1 \pm 2 \text{ Nm}$
($4.4 \pm 0.2 \text{ kgf.m}$, $31.8 \pm 1.4 \text{ lb.ft}$)

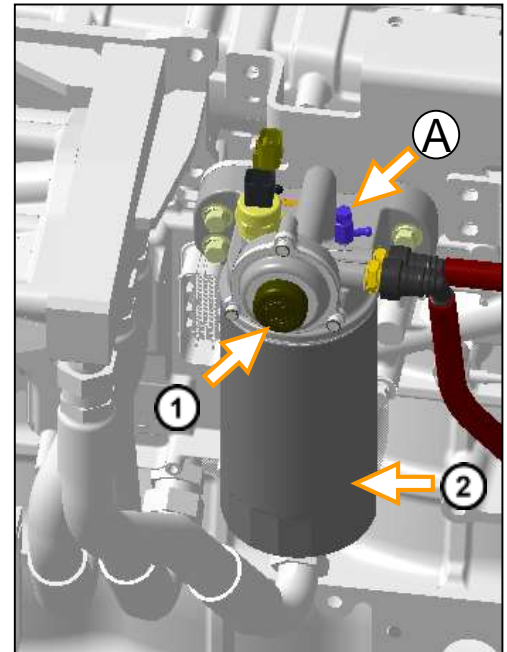

① Priming Pump

② Fuel Filter

- Pump until fuel drains from air vent, using priming pump. (Pumping time can be reduced by filling a new cartridge with fuel before mounting)
- Air bleeding of cylinder head side is not necessary when replacing a filter and generally it is possible to start the engine using the normal cranking procedure.
- Tighten the air vent bolt 'A'.
- Start the engine and check if there is fuel leakage.

CHAPTER 5
INTAKE & EXHAUST SYSTEM

The turbo-charger uses the exhaust gas to increase the output of the engine by supplying compressed air to the combustion chamber.

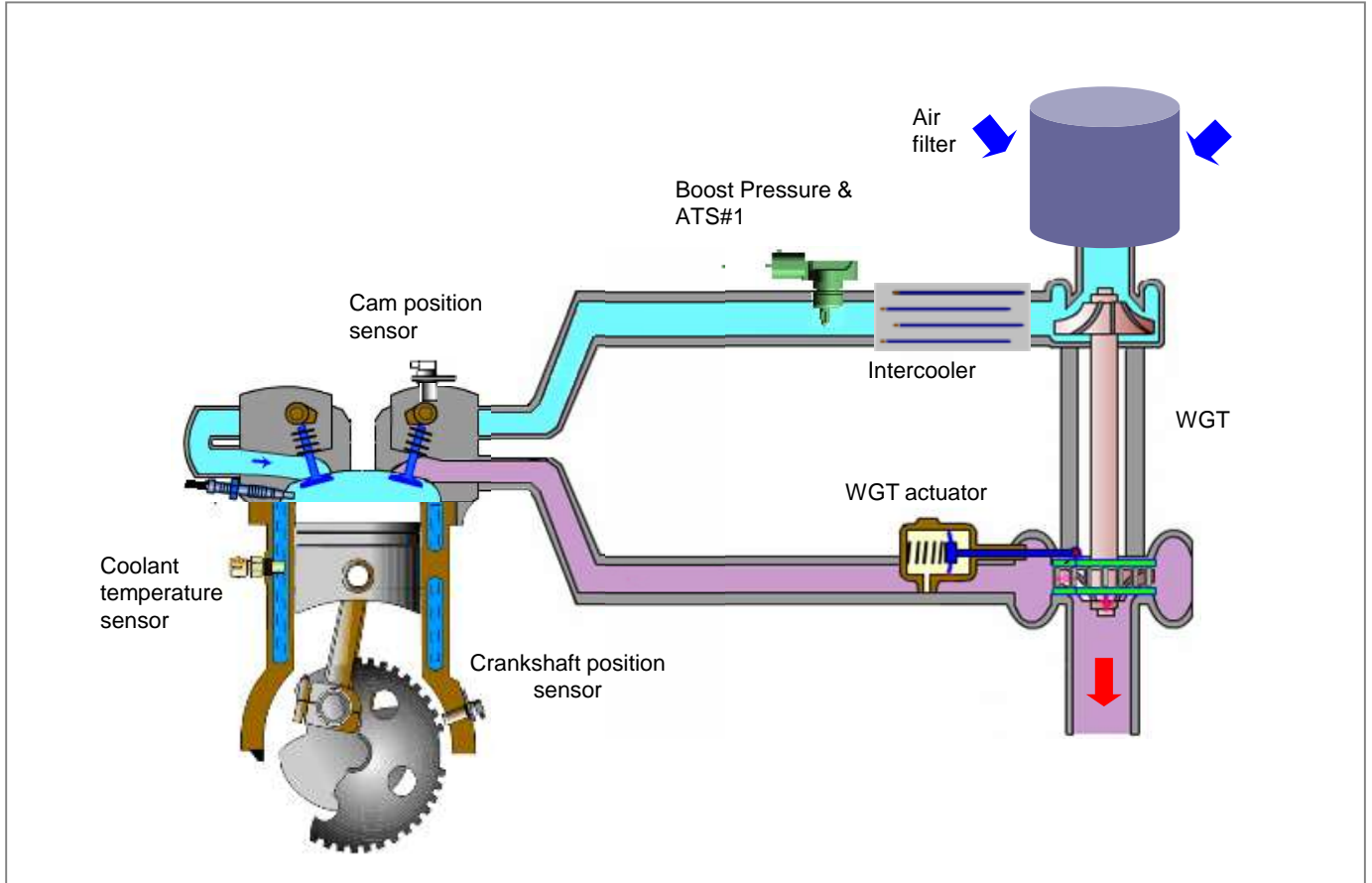

ENGINE AIR CONSUMPTION

- Engine need to proper intake air for combustion this requires a minimum internal area of air supply ducting the area can be calculated by using the formula.

<TABLE1>

Number of pipe bends (90°)	Length of pipe (Meters)				
	1	2	3	4	5
1	1	1.04	1.09	1.13	1.20
2	1.39	1.41	1.43	1.45	1.49
3	-	1.70	1.72	1.74	1.78

A = cross section of area in cm²

A = 1.9 X Engine power(KW)

→ A= 1.9 X 368(KW) = 699cm² = **Ø298.4**

- Minimum intake area is Ø298.4, when use longer ducts or more bends are used the area is corrected by multiplying by coefficient from<Table1> We recommend position of air pipe that distance 25~35cm from around air filter. Air inlet must never be installed in the transom stern. In this area is mixed with water and exhaust gases.

ex) Length of pipe : 3M , number of pipe bands : 2

→ Ø298.4 X 1.43 = Ø426.7

※ Minimum Banding R = 2 X O.D of pipe(90° cases)

ENGINE ROOM VENTILATION

- Engine room need to proper ventilation for optimum ship operation this requires a minimum internal area of air ventilation the area can be calculated by using the formula.

A = 1.65 X Engine power(KW)

→ A= 1.65 X 368(KW) = 607cm² = **Ø278**

- Minimum ventilation area is Ø278, when use longer ducts or more bends are used the area is corrected by multiplying by coefficient from<Table1> The supply for air at intake and exhaust pipe should be the same size. The Distance between air inlets and air outlets should be as long as possible. If the distance too short, results in a bad ventilation effect. The suction fan is to be installed in the exhaust air duct so that ventilate the engine room more effectively and keep low temperature in engine room.

Extraction fan capacity(Air Flow m³/min) =**0.07** X Engine power(KW)

→ Extraction fan capacity = 0.07 X 368(KW) = 25.8m³/min

※ **General pressure drop of Engine room = 0.1~0.5kPa**

ex) Length of pipe : 3M , number of pipe bands : 2

→ Ø278 X 1.43 = **Ø397.5**

CHECK AIR FILTER

- The original Hyundai SeasAll air cleaner may be cleaned and reused.
- If the air filter is very dirty, it can increase airflow resistance and reduce the flow of air to the engine. This can result in reduced power and fuel efficiency.
- Cleaning the air filter should be carried out periodically according to the procedure below.
- Do not clean the filter element with gasoline or other solvents.

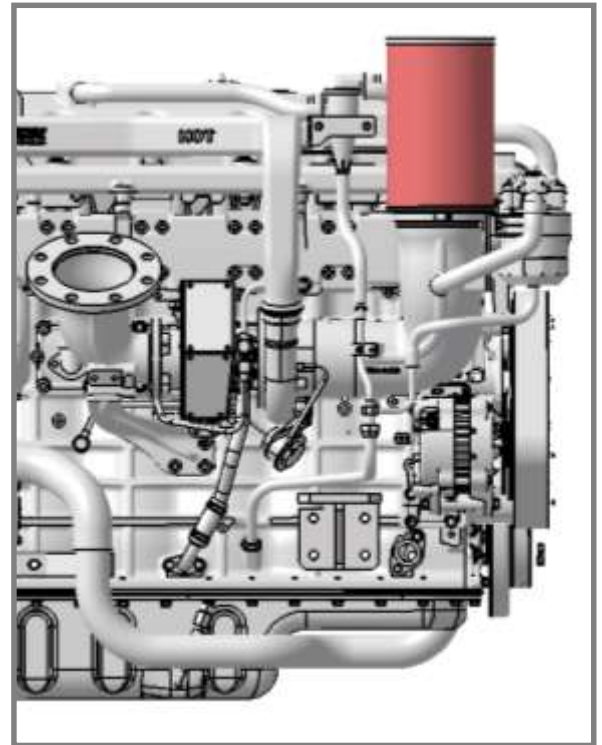

CLEANING AIR FILTER

- Remove the air filter from engine.
- Put the air filter on a flat surface and shake dust out.
- Liberally spray K&N Air Filter Cleaner onto both sides of the filter and allow to soak for 15 minutes to loosen the dirt.
- Wash out the dust with low pressure running water from the inside toward the outside.
- Dry the wet air filter in the shade for 2 to 3 hours. You can reduce drying time by blowing with a hair dryer on COLD or by blowing with low pressure compressed air.

(CAUTION) Do not use high pressure air, high pressure water or hot air to clean and/or dry the air filter. These can damage the performance of the air filter.

- Apply air cleaner oil over the outside of the filter. If too much oil is applied, it will reduce performance.
- Reassemble air filter to engine.



CAUTION

WHEN REMOVING THE AIR FILTER, BE CAREFUL THAT DUST OR DIRT DO NOT ENTER THE AIR INTAKE, OR DAMAGE MAY RESULT. DO NOT RUN WITHOUT AIR CLEANER. THIS COULD RESULT IN EXCESSIVE ENGINE WEAR. USE OF NON-GENUINE PARTS COULD DAMAGE THE TURBO CHARGER OR ENGINE.

EXHAUST SYSTEM

- DO NOT extend or bend the pipe in exhaust line excessively.
- The exhaust gas pressure should not exceed 150 mmHg @1800rpm for the best performance of the engine. Be sure that rain does not fall into the exhaust pipe.
- The exhaust pipe can be rotated per the installation requirements. Tighten the exhaust pipe to the support bracket to prevent damage from vibration.

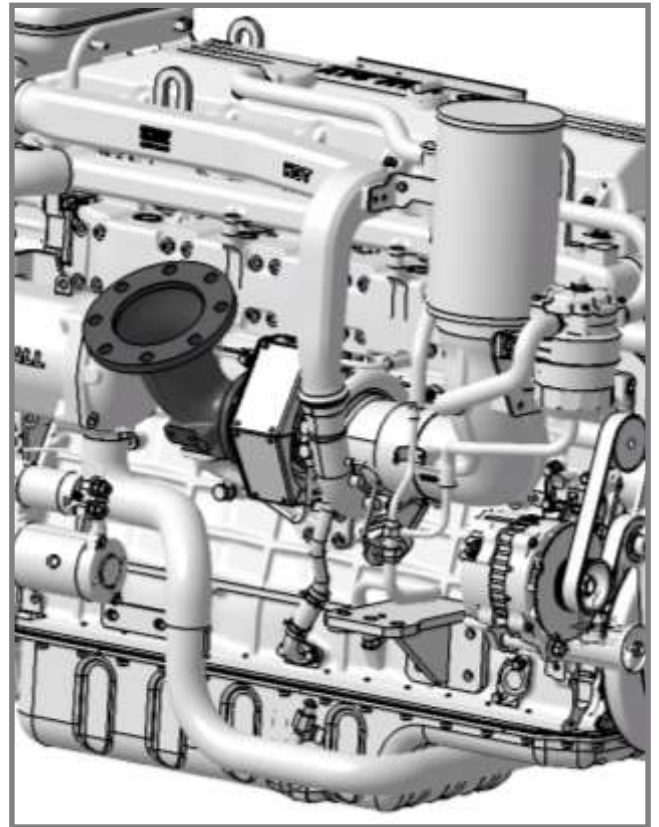

CAUTION

IF IN DOUBT ABOUT EXHAUST SYSTEM INSTALLATION, PLEASE CONTACT YOUR NEAREST HYUNDAI SEASALL DEALER.

CHAPTER 6
LUBRICATION SYSTEM

LUBRICATION COMPONENTS

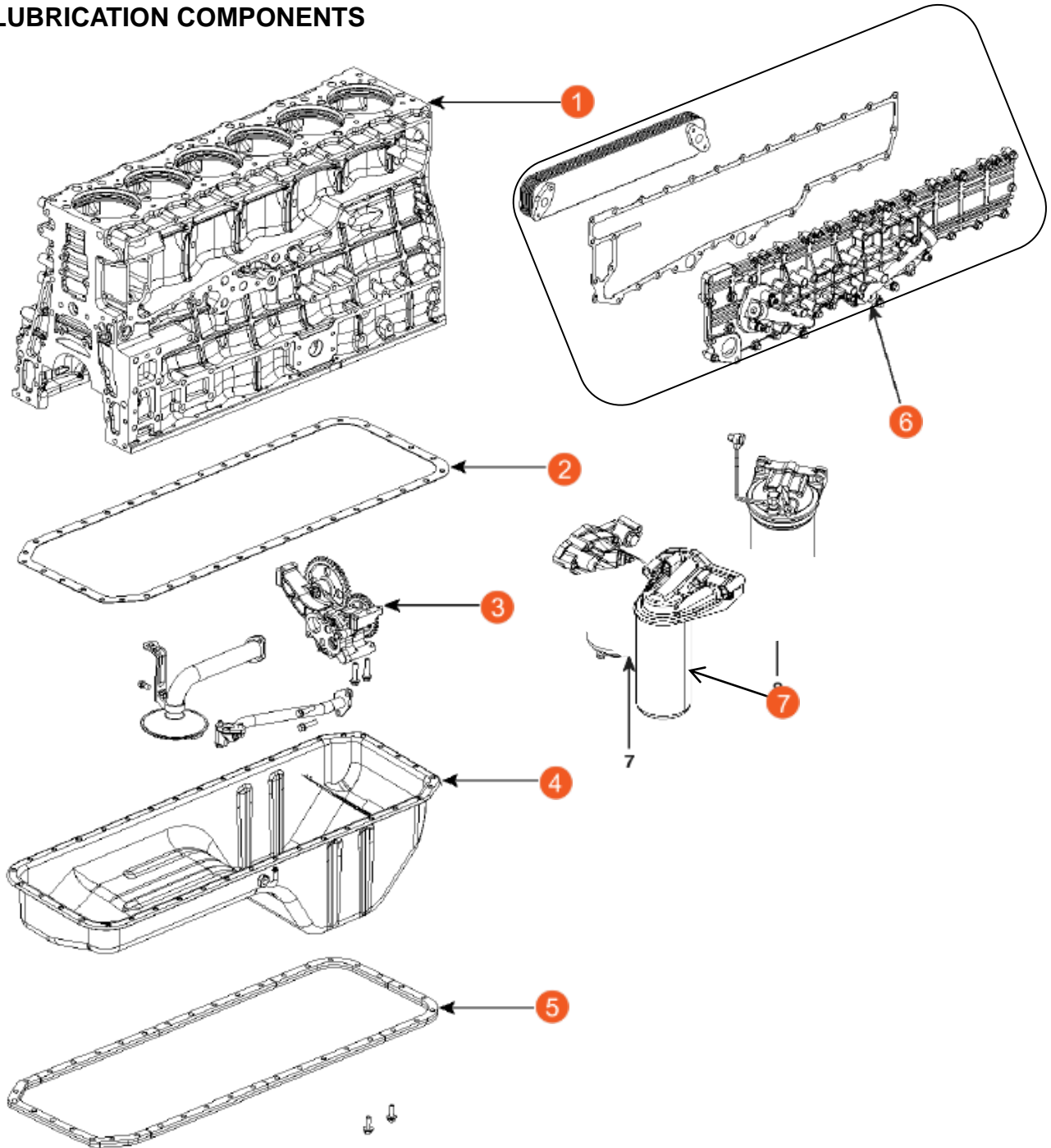

- 1 Cylinder block
- 2 Gasket
- 3 Oil pump assembly
- 4 Oil fan

- 5 Plate
- 6 Oil cooler assembly
- 7 Oil filter

ENGINE OIL LEVEL CHECKS

- The engine oil level must be checked at regular intervals.
- The dipstick's F position differs when the engine is mounted horizontally and when it is tilted (approx. 7 °) (see figure).
- Be sure the boat is level.
- Start the engine and allow it to reach normal operating temperature.
- Turn the engine off and wait about 5 minutes, until the oil has returned to the oil pan.
- Pull the dipstick out, wipe it clean, and reinsert it fully.
- Pull the dipstick out again and check the level. The level should be between F and L. If it is near or at L, add enough oil to bring the level to F. Do not fill with engine oil above the F mark.

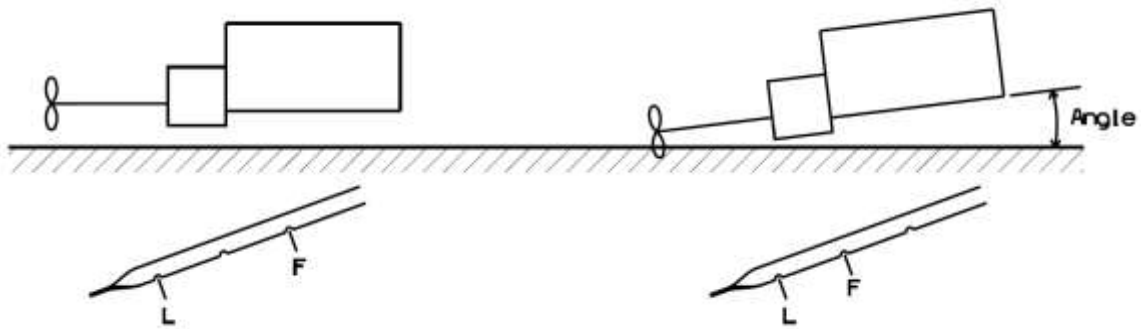

RECOMMENDED OIL QUALITY

For best performance and maximum protection during all types of operation, select only those lubricants which :

- Satisfy the requirement of the API or ACEA classification.
- Have proper SAE grade number for expected ambient temperature range.

Description		Specifications	Limit	
Oil quality	ACEA	Above B4	Service oil quality should conform to ACEA or API classification.	
	API	CI – 4 or higher		
	SAE		15W-40	-15°C above
			10W-30	-20°C ~ 40°C
			5W-30	-25°C ~ 40°C
		0W-30	10°C below	

ENGINE OIL EXTRACTION PUMP

- Allow the engine to warm up at least 5 minutes then turn off engine.
- Remove the engine oil filler cap and oil filter.
- The oil drain hose is connected to the oil extraction pump ①. Route the loose end of the hose into the container being used for the oil change ②.
- Turn the ignition key on (but do NOT start the engine) then press and hold the button ③ until the engine oil is completely pumped out.
- When you stop pushing the button, the pump will turn off.

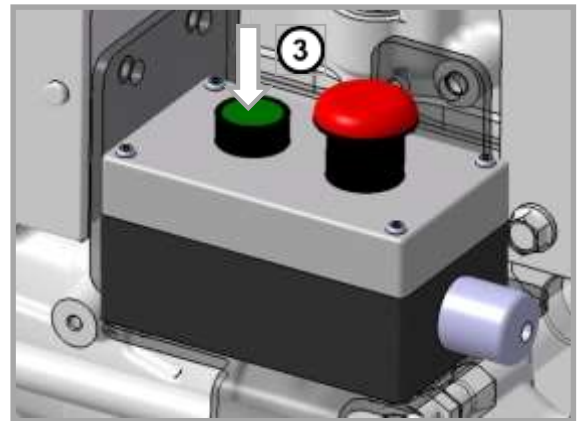
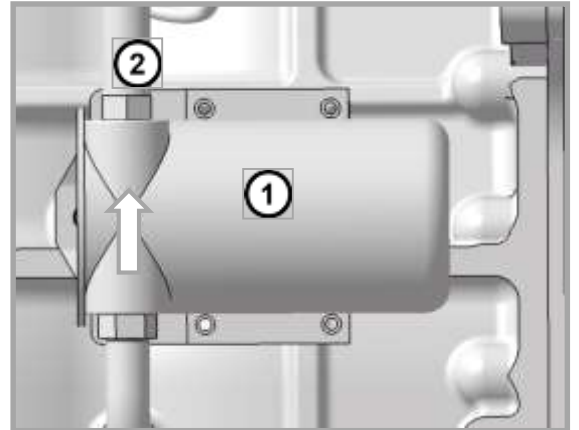

CHECKING OIL FILTER

- Draining the Oil
- Remove existing oil filter.
- Apply oil to the O-ring of the new filter.
- Assemble the filter to housing using a filter wrench.
- Pour in new oil and check the oil level.
- Run the engine and look for leaks.
- Turn off the engine and check the oil level. add oil if necessary.

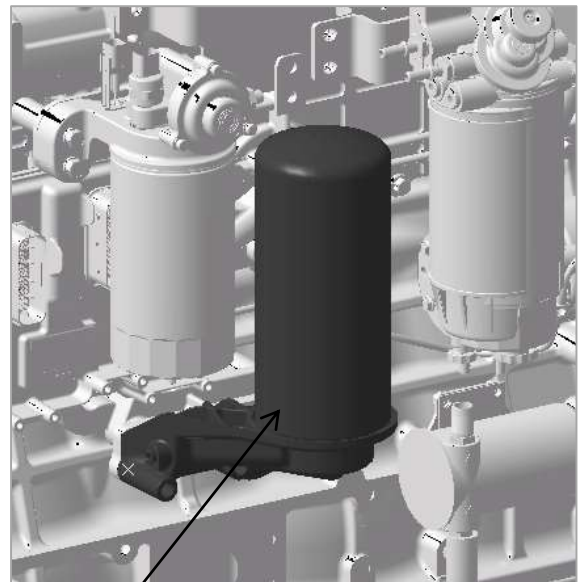

OIL FILTER



WARNING

USED OIL MUST BE STORED IN A SAFE PLACE AWAY FROM CHILDREN AND SOURCES OF IGNITION. IF YOU HAVE A USED OIL DISPOSAL PROBLEM, PLEASE HAVE THE ENGINE OIL CHANGED BY YOUR NEAREST HYUNDAI SEASALL SERVICE DEALER.

CHAPTER 7 ELECTRICAL SYSTEM

BATTERY CABLE CONNECTIONS

- 1) The diameter of battery cable should be at least 40mm² within a length of 4m.
- 2) And it should be at least 50mm² if the cable is longer than 4m.
- 3) Recommended battery capacity is over 100 amperes.
- 4) Connect the battery (+) cable to the start motor.
- 5) Connect the battery (-) cable to block ground.
- *In case of a "Two Pole System", connect battery (-) cable to the isolated ground)**
- 6) Battery cables should be clean and tightly connected.

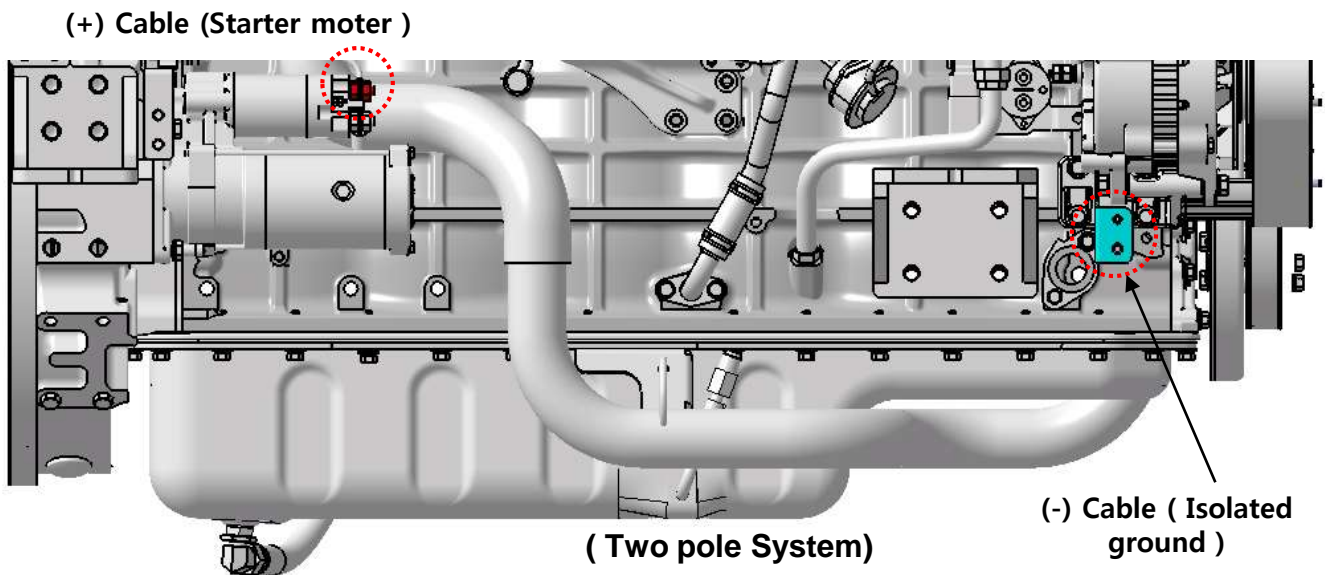
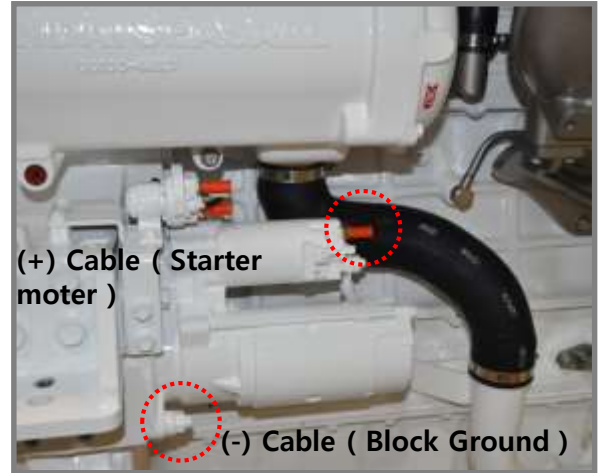

CAUTION

DO NOT TOUCH OR REMOVE ELECTRICAL PARTS WHEN STARTING OR DURING OPERATION.
KEEP HANDS, HAIR, AND CLOTHES AWAY FROM THE FLYWHEEL AND OTHER ROTATING PARTS WHILE THE ENGINE IS RUNNING.

ACCELERATION SENSOR AND CONTROL LEVER

When installing control lever cable to acceleration sensor, be sure that the acceleration sensor lever is fully released to the idle position and fully pulled to the full-load position. The swing distance of lever between idle and full-load position is 40mm.

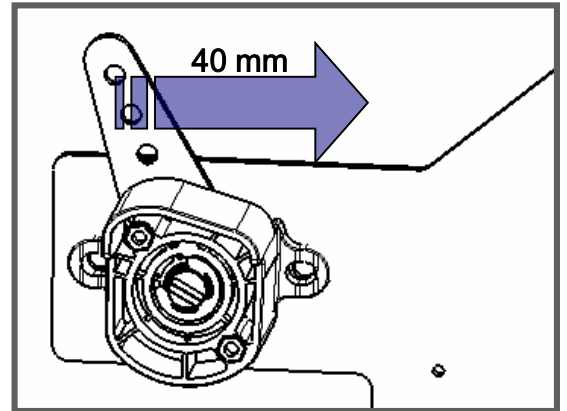

PROCEDURES FOR CONTROL LEVER INSTALLATION

- Idle position setting

Make sure that the position value indicates 0% in the neutral position.

- Full load position setting

Make sure that the position value indicates full load range of 100% at full forward lever position. If not, disassemble and adjust the base neutral position of the control lever by moving it to the rear until the conditions are met.

- You can see the value of lever position on the LCD display of rpm gauge as well as EOI.

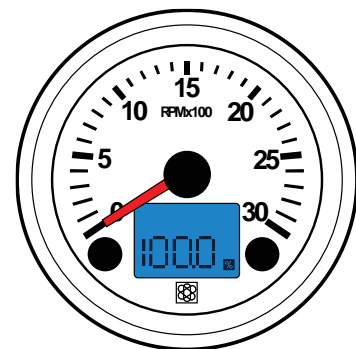
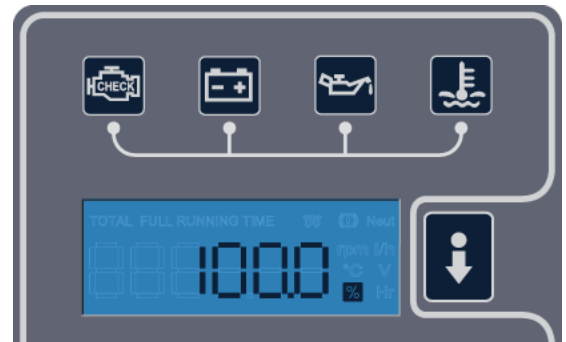

CAUTION

YOU SHOULD PERFORM ABOVE PROCEDURES AFTER CONTROL LEVER INSTALLATION WITH THE ENGINE NOT RUNNING BUT WITH THE IGNITION KEY ON.

BATTERY CHECKS

Battery inspection is very important in electronically controlled engines. You must check the battery condition regularly.

LOAD TEST

• Connect the load tester clamps to the terminals and proceed with the test as follows.

- ① If the battery has been charged, remove the surface charge by connecting a 300 ampere load for 15 seconds.
- ② Connect the voltmeter and apply the specified load.
- ③ Read the voltage after the load has been applied for 15 seconds.
- ④ Disconnect the load.
- ⑤ Compare the voltage reading with the minimum acceptable voltage shown in the table. If the voltage is greater than shown in the table, the battery is good. If the voltage is less than shown in the table, replace the battery.

Voltage	Temperature
18.5 V	20°C (70°F) and above
18.4 V	16°C (60°F)
18.3 V	10°C (50°F)
18.1V	4°C (40°F)
17.9 V	-1°C (30°F)
17.7 V	-7°C (20°F)
17.8 V	-12°C (10°F)
17.5 V	-18°C (0°F)



WARNING

BATTERY MUST BE STORED AND WORKED ON IN A SAFE PLACE AWAY FROM CHILDREN AND SOURCES OF IGNITION. FLUID IN THE BATTERY IS A CORROSIVE ACID AND MUST BE HANDLED WITH CARE. IF SPILLED ON ANY PART OF THE BODY, FLUSH IMMEDIATELY WITH WATER.



CAUTION

DO NOT LOOSEN OR DETACH BATTERY TERMINALS WHILE ENGINE IS RUNNING. DOING SO WILL DAMAGE THE CHARGING SYSTEM AND OTHER ELECTRONIC DEVICES.

FUSES AND RELAYS

SYSTEM FUSE BOX (IN JUNCTION BOX)



1 SYSTEM FUSE BOX (IN JUNCTION BOX)

- ALT_40Amp (Alternator)
- ALT_40Amp (Alternator)

2 FUSE BOX(IN JUNCTION BOX)

- Ignition power : 5 Amp
- Main power : 20 Amp
- Air heater auxiliary : 5 Amp
- Starter auxiliary : 5 Amp
- Fuel heater : 20 Amp



FUSES

- An engine’s electrical system is protected from electrical overload damage by fuses.
- If a fuse has blown, the element inside the fuse will be melted. If the electrical system does not work, first check the fuses in ECU box. Always replace a blown fuse with one of the same rating.
- If the replacement fuse blows, this indicates an electrical problem. Avoid using the system involved and immediately consult a Hyundai SeasAll dealer.



RELAYS

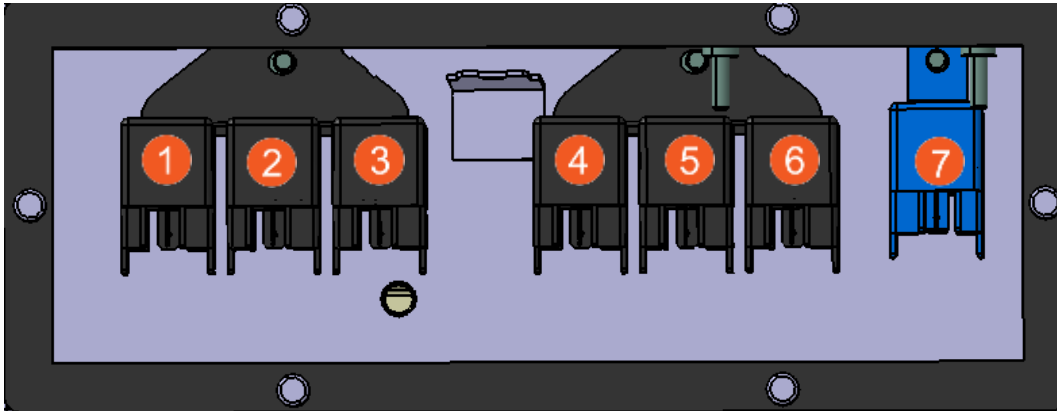

- | | |
|--|---|
| <ul style="list-style-type: none"> 1 Reserve-20Amp 2 Main-20Amp 3 Fuel heater-20Amp 4 Oil pump-20Amp | <ul style="list-style-type: none"> 5 Air heater-20Amp 6 Starter solenoid-20Amp 7 Power key-20Amp(5Pin) |
|--|---|

- Using an ohmmeter, check that there is continuity between each terminal.

Terminal	Continuity
30 - 87	NO
30-87a	YES
85 - 86	YES

- Grounded to terminal 85 by supply 24V to terminal 86.
- Check for continuity between terminals 30 and 87.
- Always replace a damaged relay with one of the same rating.

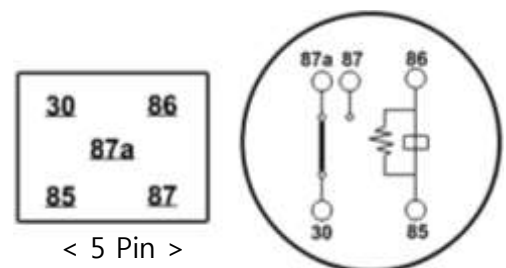
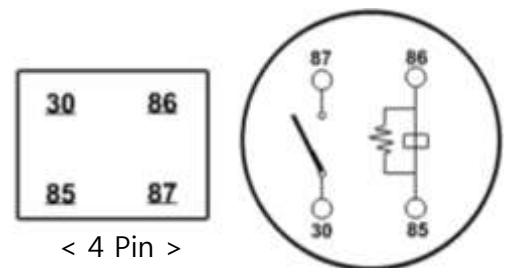

CHAPTER 8 EOI SYSTEM

The Engine Operating Indicator (EOI) system gives you a lot of information about the engine's current operation. You can hear alarm beeps and see information including RPM, coolant temperature, warning lamps, error codes and engine working time. If the switch is on, warning lamps for battery, engine oil, etc. flash. When the engine starts normally, all the lamps turn off. If there is a problem, the specific lamp will come on. In this case, contact your Hyundai SeasAll dealer and have the engine checked as soon as possible.

INSTRUMENT CONNECTIONS

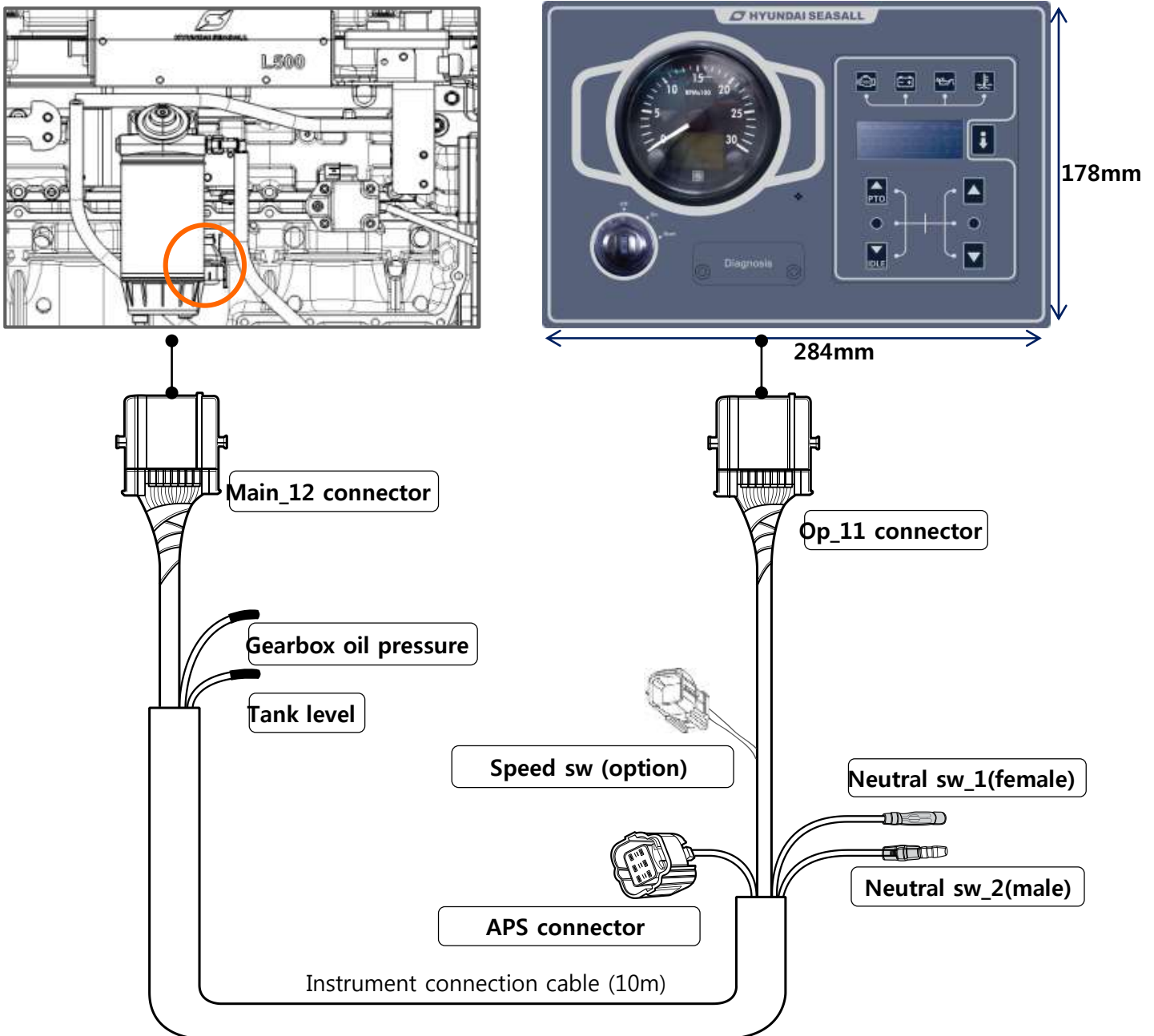

※ If there is no neutral switch, you must connect the neutral switch-1 and neutral switch-2 of the instrument connection cable.

RPM GAUGE

- 1) When the ignition key is in the ON position, this gauge will work.
- 2) This gauge indicates real-time engine rpm.
- 3) Avoid maximum rpm and Wide Open Throttle (WOT) before a cold engine is fully warmed up as it can harm the engine.

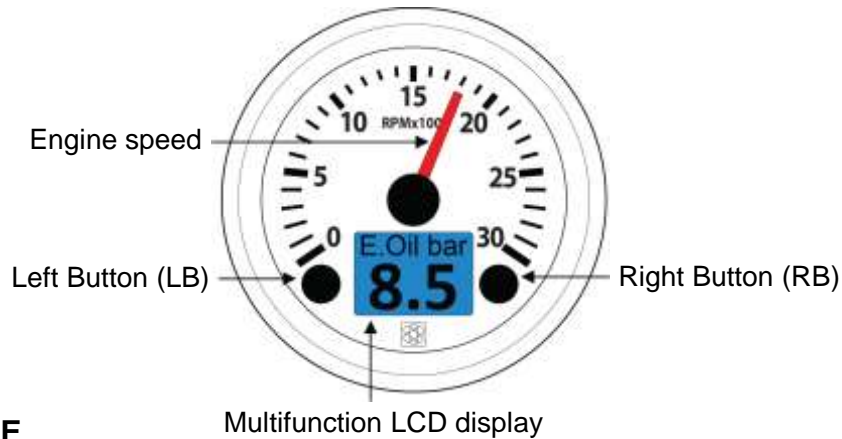

USER INTERFACE

- 1) Press the LB/RB button to cycle through the display as shown below
- 2) If there is a problem with the engine, the multifunction LDC display shows the related symbol and alarm.

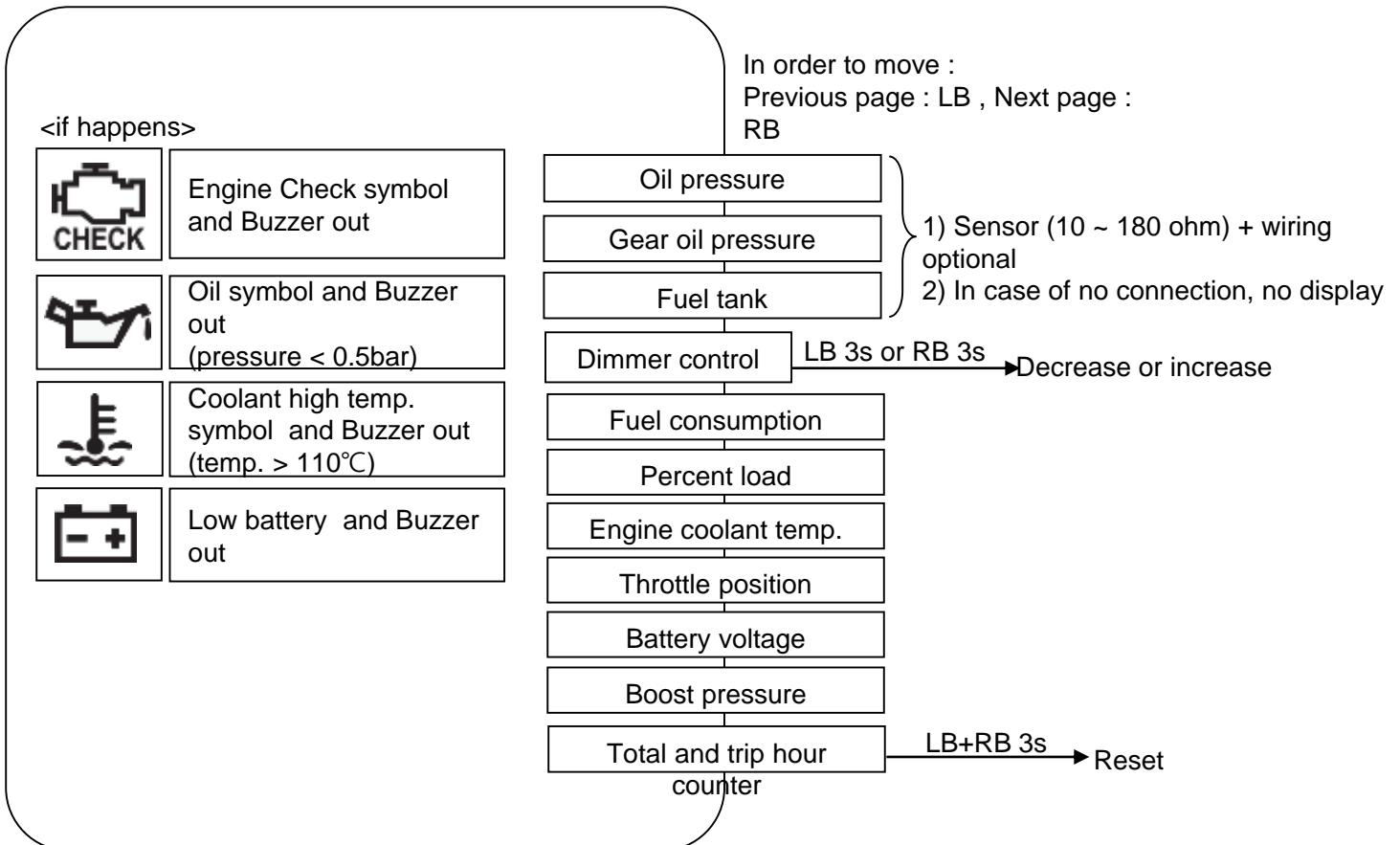

EOI FUNCTION

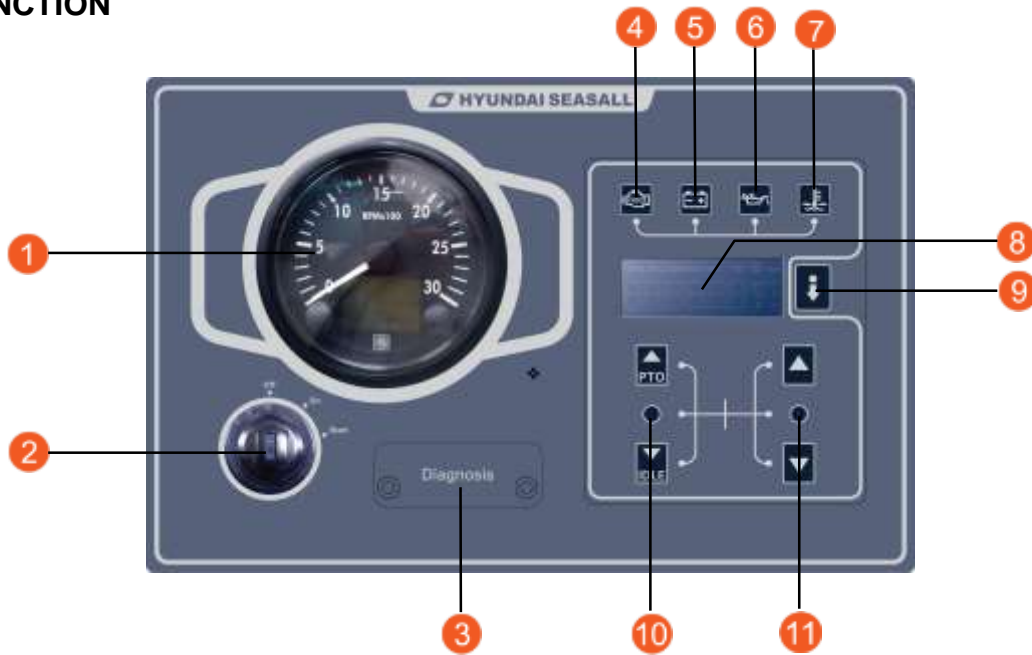

- | | |
|------------------------------|--|
| 1) RPM gauge | 7) Coolant high temperature warning lamp |
| 2) Key switch | 8) LCD information |
| 3) G scan terminal port | 9) Function switch |
| 4) Check engine lamp | 10) PTO / IDLE Change switch |
| 5) Charging warning lamp | 11) PTO / IDLE RPM Up / Down switch |
| 6) Oil pressure warning lamp | |

LCD INFORMATION

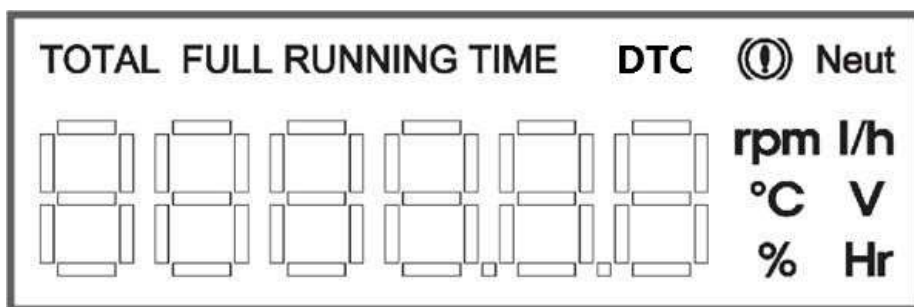

- | | |
|---|-----------------------------|
| 1) Total engine full throttle time (Hr) | 4) Engine coolant temp (°C) |
| 2) Throttle position (%) | 5) Battery voltage (V) |
| 3) Diagnosis Trouble Code (DTC) | 6) Engine RPM (rpm) |

WARNING LAMPS

Alarm will sound when alarm lamps flicker.

CHECK ENGINE

- This lamp informs you that the engine has a serious problem.
- You can see the DTC on the LCD of the EOI .
- The ECU may limit the engine performance to protect the engine in some cases. You should check the engine at the nearest Hyundai SeasAll dealer immediately.

CHARGING WARNING

- This lamp informs you that charging circuit has a problem (such as with the alternator).
- If this lamp is turned on, you should stop the engine and eliminate electric load, as well as check the alternator, drive belt system and wiring system.

OIL PRESSURE WARNING

- This lamp informs you if the engine oil pressure is low.
- If this lamp is on, you should stop the engine and check the oil level with the oil gauge (dip stick). If the oil is low, refill it. If you refill the oil and the lamp still does not turn off, you should ask your Hyundai SeasAll dealer for maintenance.

COOLANT TEMPERATURE WARNING

- This lamp informs you that the engine coolant is abnormally high (110°C +).
- If the lamp is on, you should stop the engine immediately and check with the nearest Hyundai SeasAll dealer immediately.
- It can be harmful to drive your engine with this lamp on.

SWITCHES

- 1) Function switch - use to change the information display on the LCD.
- 2) PTO / IDLE change switch – use to enable PTO / IDLE RPM adjustment function
- 3) UP / DOWN switch – use to raise or lower PTO / IDLE RPM.

PTO MODE

- 1) Used to adjust the fixed RPM of PTO.
- 2) When PTO switch is ON, engine speed will be upgraded 700RPM (initial RPM) .
- 3) You can adjust the RPM using the UP / DOWN switch.
- 4) When PTO switch is OFF, engine speed will be returned to the value set for IDLE RPM.
- 5) Adjustable RPM area : 700 RPM ~ 1900 RPM

IDLE SETTING MODE

- 1) Used to adjust the IDLE RPM.
- 2) Operate IDLE switch on Quiescent state.
- 3) When the switch moved to the UP or DOWN position, RPM value increases or decreases by increments of 25 RPM.
- 4) When IDLE switch is OFF, IDLE RPM value will be returned to the initial RPM value.
- 5) Adjustable RPM area : 600RPM ~ 800RPM.

If you need to change the IDLE RPM value in the range of 600 RPM to 500 RPM, the value can be changed using the G-SCAN. Contact your Hyundai-SeasAll dealer.

EOI BOX (INSIDE)

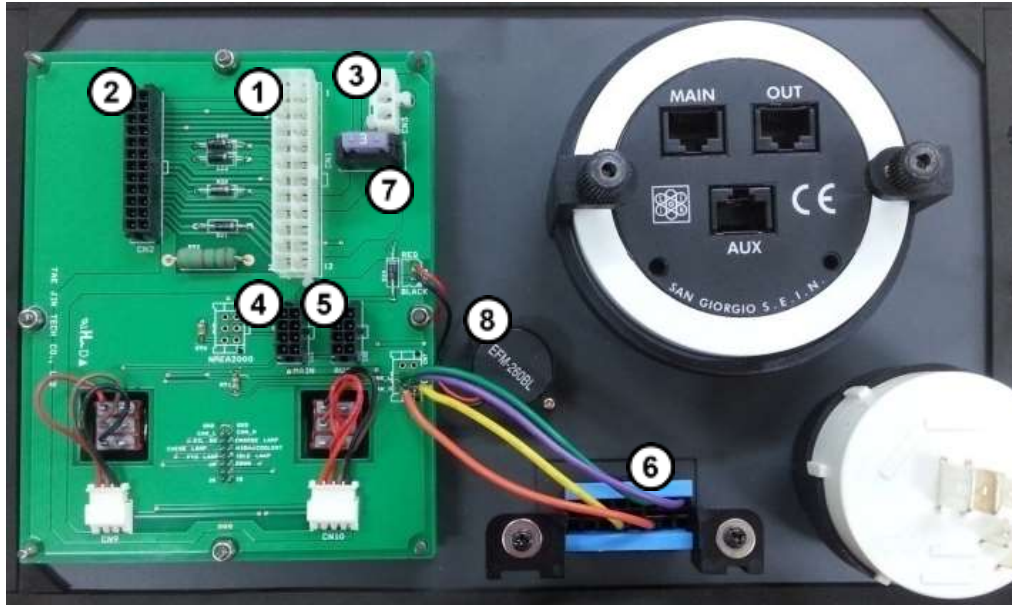

- ① Connection Plug – CN1 (Engine Main Connector)
- ② Connection Plug – CN2 (Inspect Terminal)
- ③ Connection Plug – CN3 (Key Switch)
- ④ Connection Plug – CN4 (RPM Gauge-Main)
- ⑤ Connection Plug – CN5 (RPM Gauge-Aux)
- ⑥ Connection Plug – CN6 G-SCAN Connector Terminal)
- ⑦ System power fuse(3A)
- ⑧ Buzzer

CUT-OUT FOR EOI SYSTEM

You can use an installation template enclosed with the EOI for a cut-out.



WARNING

LISTEN FOR A CLICK WHEN LOCKING CONNECTORS. THIS SOUND INDICATES THAT THEY ARE SECURELY LOCKED.



CAUTION

DO NOT CONNECT EXTRA INSTRUMENTS WHICH DRAW OVER 1 AMPERE. THE E.O.I WILL BE DAMAGED BY OVERLOAD.

EOI PIN ASSIGNMENT

CN1 (ENGINE MAIN CONNECTOR)

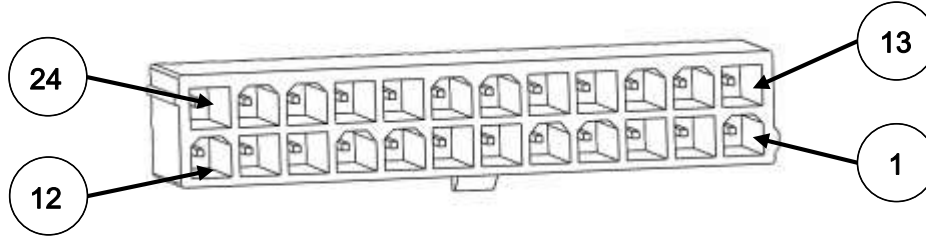

- | | |
|------------------------|----------------------------|
| 1. GROUND | 13. NEUTRAL SWITCH 2 |
| 2. IDLE SWITCH | 14. CAN 1-L |
| 3. PTO LAMP | 15. GEARBOX OIL PRESSURE |
| 4. OIL PRESSURE SENDER | 16. START SWITCH |
| 5. OIL PRESSURE SWITCH | 17. CHARGE WARNING LAMP |
| 6. CLUTCH SWITCH | 18. PTO SWITCH |
| 7. CAN 1-H | 19. PTO RES/DEC |
| 8. BATTERY + | 20. CHECK LAMP |
| 9. CAN 2-H | 21. PTO SEC/INC |
| 10. CAN 2-L | 22. TANK LEVEL |
| 11. NEUTRAL SWITCH 1 | 23. HIGH COOLANT TEMP LAMP |
| 12. KEY SWITCH | 24. NOT USED |

CN2 (INSPECTION TERMINAL)

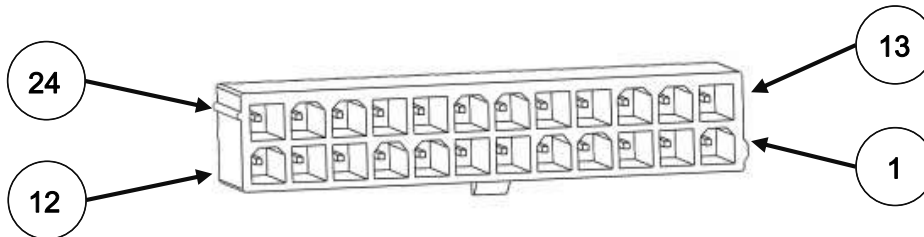

- | | |
|------------------------|----------------------------|
| 1. GROUND | 13. NEUTRAL SWITCH2 |
| 2. IDLE SWITCH | 14. CAN 1-L |
| 3. PTO LAMP | 15. GEARBOX OIL PRESSURE |
| 4. OIL PRESSURE SENDER | 16. START SWITCH |
| 5. OIL PRESSURE SWITCH | 17. CHARGE WARNING LAMP |
| 6. CLUTCH SWITCH | 18. PTO SWITCH |
| 7. CAN 1-H | 19. PTO RES/DEC |
| 8. BATTERY + | 20. CHECK LAMP |
| 9. CAN 2-H | 21. PTO SEC/INC |
| 10. CAN 2-L | 22. TANK LEVEL |
| 11. NEUTRAL SWITCH1 | 23. HIGH COOLANT TEMP LAMP |
| 12. KEY SWITCH | 24. NOT USED |

CN3 (KEY SWITCH)

1. KEY SWITCH
2. START SWITCH
3. BATTERY +

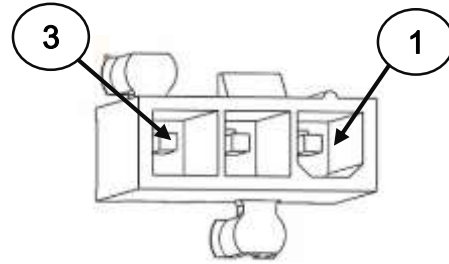

CN4 (RPM Gauge-Main)

1. BATTERY +
2. NOT USED
3. GROUND
4. KEY SWITCH
5. DIMMER
6. CAN 1-H
7. CAN 1-L
8. NOT USED

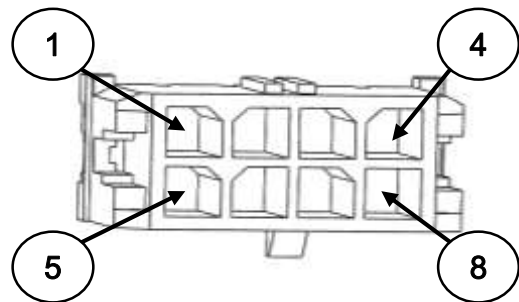

CN5 (RPM Gauge-Aux)

1. NOT USED
2. BUZZER
3. OIL PRESSURE SENDER
4. NOT USED
5. GEARBOX OIL PRESSURE
6. NOT USED
7. NOT USED
8. TANK LEVEL

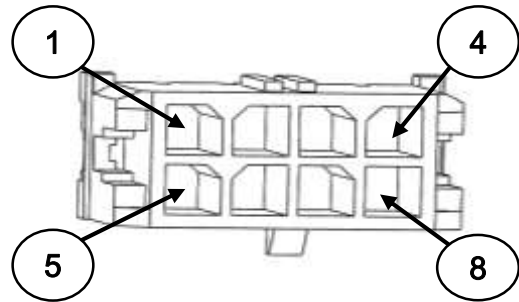

CN7 (Diagnosis)

1. CAN 2-H
2. CAN 2-L
3. NOT USED
4. GROUND
5. BATTERY +
6. NOT USED

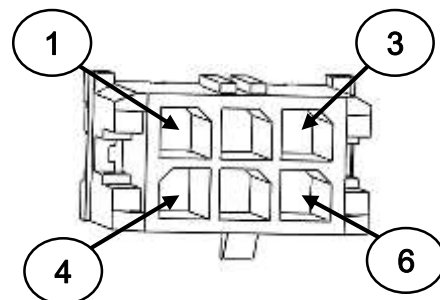

SEASLINK PRODUCT COMPONENTS

1) SeasLINK Dongle



Bluetooth 4.0 communication



2) Smart phone application "SeasLINK"



- Engine Information**
- Ship's Log**
- Diagnosis**
- Transmit Fault Data**
- Group boating**

WIFI or Mobile Network



3) Web site
" seaslink.hyundai-seasall.com"



INSTALLATION OF SEASLINK DONGLE

Install the SeasLINK dongle for communication between the engine and your smart phone. The dongle should be installed on the diagnosis connector (OBD Terminal) of the EOI. If you use the diagnosis tool, PLEASE REMOVE SEASLINK DONGLE.



▪ **DOWNLOAD APPLICATION**

- 1) Android (Search word at Play Store : **seaslink**)
 - At least android OS version Kitkat (4.4.2)
 - Check : Settings → About phone → Software information

- 2) iPhone (Search word at App Store : **seaslink**)
 - At least iPhone 4S

▪ **CREATE AN ACCOUNT**

- 1) Access on web page
 - Visit our website on your PC or smart phone
"seaslink.hyundai-seasall.com"



- 2) Create ID/PW
 - Click 'Create an account' icon and create your account. ID and PW will be used for the application.



- 3) SeasLINK login
 - Input ID and PW on your smart phone application.



G-SCAN

G-scan is a diagnostic tool which can perform the functions of DTC analysis, fault code searching, data analysis and ECU upgrading.



G-SCAN CONNECTIONS

The G-scan can be connected to the diagnostic connector of the EOI (1), as well as to the G-scan connector in the junction box (2).

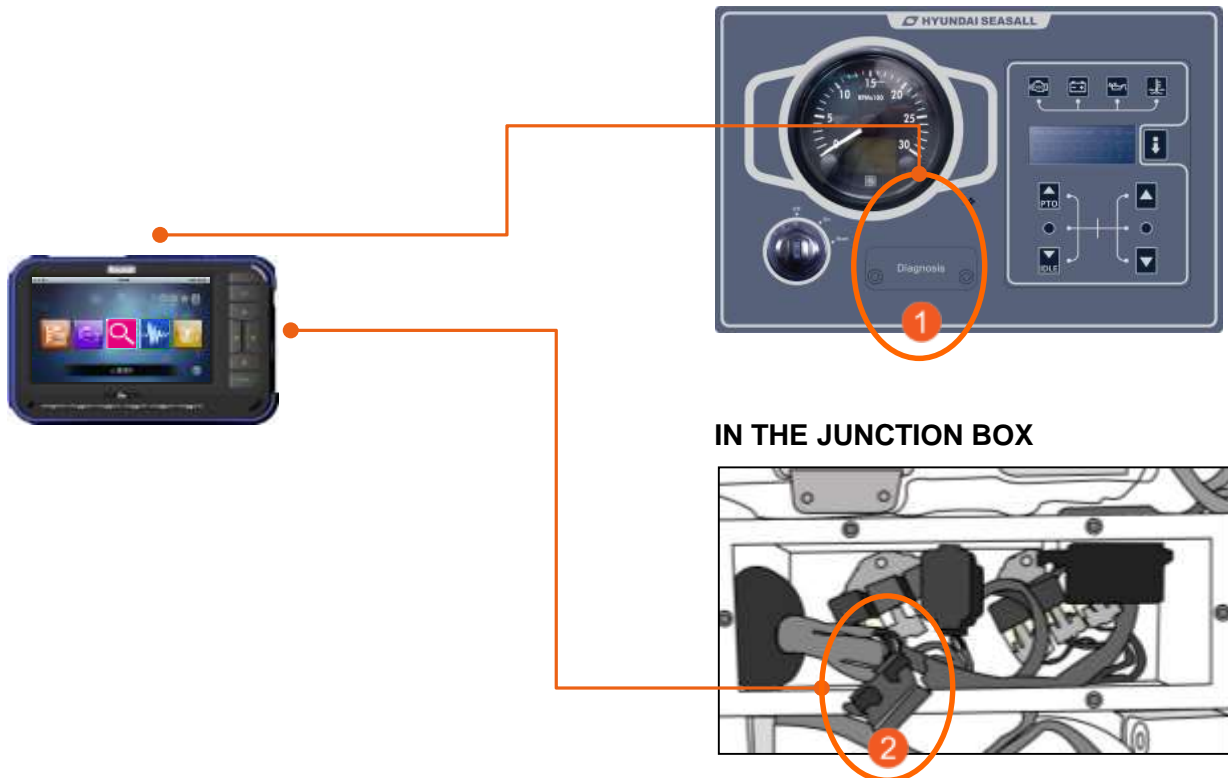

DIAGNOSTIC TROUBLE CODE (DTC) AND ALARM LIST

If there is a problem in the engine, the EOI display (audible or visible) alarm and related DTC will give you information about it. The DTC display is only for initial assistance and to aid communication with a Hyundai SeasAll dealer if there is an emergency. You should contact your nearest Hyundai SeasAll dealer as soon as possible if a system problem arises.

NO.	ITEM	DTC DISRIPTION	P-CODE	FAIL SAFE & DEFAULT VALUE	WARNING LAMP	BUZZER
1	Accelerator lever	Sensor Reference Voltage "A" Circuit Low	P0642	<ul style="list-style-type: none"> ▪RPM 700 Fixed ▪ Sensor Default Value : 0V, 0% 	○	○
2		Sensor Reference Voltage "A" Circuit High	P0643		○	○
3		Throttle/Pedal Position Sensor "A" Minimum Stop Performance	P2109		○	○
4		Throttle Actuator Control System - Forced Limited RPM	P2110		○	○
5	Air Heater	Intake Air Heater "A" Circuit Low	P0541	Bad cold-start		
6		Intake Air Heater "A" Circuit High	P0542			
7		Intake Air Heater "A" Circuit Open	P0543			
8		Intake Air Heater System Performance	P2609			
9	Alternator	Charging System Voltage High	P2504	Fixed to Engine Idle RPM	○	○
10	Ambient air Pressure	Barometric Pressure Circuit Low Input	P2228	Sensor Default Value : 100kpa		
11		Barometric Pressure Circuit High Input	P2229			
12	Boost Pressure (Manifold Absolute Pressure)	Manifold Absolute Pressure Circuit Low Input	P0107	<ul style="list-style-type: none"> ▪ Engine Power Limitation ▪ Sensor Default Value : 150kpa 	○	○
13		Manifold Absolute Pressure Circuit High Input	P0108		○	○
14		Manifold Absolute Pressure Plausible Fault	P1106		○	○
15	CAM & CRANK SENSOR	Camshaft Position Correlation Fault	P0016	<ul style="list-style-type: none"> ▪ Engine Power Limitation ▪ Injection Timing Fixed to BTDC 6 	○	○
16		Crankshaft Position Position Correlation Fault	P0017		○	○
17		Crankshaft Position Sensor "A" Circuit	P0335		○	○
18		Camshaft Position Sensor "A" Circuit	P0340		○	○
19	ECU	Internal Control Module Memory Check Sum Error	P0601	Engine Running Impossible	○	○
20		ECU Safety Circuit integrity checks Error	P060A		○	○
21		Fuel Injector Group "A" Supply Voltage Circuit Low	P2147		○	○
22		Fuel Injector Group "A" Supply Voltage Circuit High	P2148		○	○

NO.	ITEM	DTC DISRIPTION	P-CODE	FAIL SAFE & DEFAULT VALUE	WARNING LAMP	BUZZER
23	Engine Coolant Temperature	Engine Coolant Temperature Circuit Low Input	P0117	Sensor Default Value - Key on & Starting : - 10°C - Driving : 100°C		
24		Engine Coolant Temperature Circuit High Input	P0118			
25		Engine Coolant Over Temperature Condition	P0217	Engine Power Limitation over 110°C	○	○
26	Fuel Pressure	Low Pressure Fuel System Sensor Circuit Low	P2541	Sensor Default Value : 350Kpa	○	○
27		Low Pressure Fuel System Sensor Circuit High	P2542		○	○
28	Fuel Pump	Fuel Pressure Level 1 Derate	P1087	Engine Power Limitation		
29		Fuel Pressure Level 2 Derate	P1088		○	○
30		Fuel Pressure Level 3 Derate	P1089		○	○
31	Fuel Temperature	Fuel Temperature Sensor "A" Circuit Low Input	P0182	Sensor Default Value : 40°C		
32		Fuel Temperature Sensor "A" Circuit High Input	P0183			
34	Engine check lamp & Engine over-heated lamp	Engine Check lamp circuit Low	P1653	Lamp not working		
35		High Coolant Temperature Lamp	P1656	Lamp not working		
36	Injector	Injector Needle "1" High side circuit Low - Cylinder 1	P1201	No Injection	○	○
37		Injector Needle "1" High side circuit High - Cylinder 1	P1202		○	○
38		Injector Needle "1" Low side circuit Low - Cylinder 1	P1203		○	○
39		Injector Needle "1" Low side circuit High - Cylinder 1	P1204		○	○
40		Injector Needle "2" High side circuit Low - Cylinder 5	P1205	No Injection	○	○
41		Injector Needle "2" High side circuit High - Cylinder 5	P1206		○	○
42		Injector Needle "2" Low side circuit Low - Cylinder 5	P1207		○	○
43		Injector Needle "2" Low side circuit High - Cylinder 5	P1208		○	○
44		Injector Needle "3" High side circuit Low - Cylinder 3	P1209	No Injection	○	○
45		Injector Needle "3" High side circuit High - Cylinder 3	P1210		○	○
46		Injector Needle "3" Low side circuit Low - Cylinder 3	P1211		○	○
47		Injector Needle "3" Low side circuit High - Cylinder 3	P1212		○	○
48		Injector Needle "4" High side circuit Low - Cylinder 6	P1213	No Injection	○	○
49		Injector Needle "4" High side circuit High - Cylinder 6	P1214		○	○
50		Injector Needle "4" Low side circuit Low - Cylinder 6	P1215		○	○
51		Injector Needle "4" Low side circuit High - Cylinder 6	P1216		○	○

NO.	ITEM	DTC DISRIPTION	P-CODE	FAIL SAFE & DEFAULT VALUE	WARNING LAMP	BUZZER
52	Injector	Injector Needle "5" High side circuit Low – Cylinder 2	P1217	No Injection	<input type="radio"/>	<input type="radio"/>
53		Injector Needle "5" High side circuit High - Cylinder 2	P1218		<input type="radio"/>	<input type="radio"/>
54		Injector Needle "5" Low side circuit Low - Cylinder 2	P1219		<input type="radio"/>	<input type="radio"/>
55		Injector Needle "5" Low side circuit High - Cylinder 2	P1220		<input type="radio"/>	<input type="radio"/>
56		Injector Needle "6" High side circuit Low - Cylinder 4	P1221	No Injection	<input type="radio"/>	<input type="radio"/>
57		Injector Needle "6" High side circuit High - Cylinder 4	P1222		<input type="radio"/>	<input type="radio"/>
58		Injector Needle "6" Low side circuit Low - Cylinder 4	P1223		<input type="radio"/>	<input type="radio"/>
59		Injector Needle "6" Low side circuit High - Cylinder 4	P1224		<input type="radio"/>	<input type="radio"/>
60		Injector Needle "1,3,5" High side circuit Low - Cylinder 1,2,3	P1225	No Injection	<input type="radio"/>	<input type="radio"/>
61		Injector Needle "1,3,5" High side circuit High - Cylinder 1,2,3	P1226		<input type="radio"/>	<input type="radio"/>
62		Injector Needle "2,4,6" High side circuit Low - Cylinder 4,5,6	P1227		<input type="radio"/>	<input type="radio"/>
63		Injector Needle "2,4,6" High side circuit High - Cylinder 4,5,6	P1228		<input type="radio"/>	<input type="radio"/>
64		Injector Spill "1" High side circuit Low - Cylinder 1	P1229	No Injection	<input type="radio"/>	<input type="radio"/>
65		Injector Spill "1" High side circuit High - Cylinder 1	P1230		<input type="radio"/>	<input type="radio"/>
66		Injector Spill "1" Low side circuit Low - Cylinder 1	P1231		<input type="radio"/>	<input type="radio"/>
67		Injector Spill "1" Low side circuit High - Cylinder 1	P1232		<input type="radio"/>	<input type="radio"/>
68		Injector Spill "2" High side circuit Low - Cylinder 5	P1233	No Injection	<input type="radio"/>	<input type="radio"/>
69		Injector Spill "2" High side circuit High - Cylinder 5	P1234		<input type="radio"/>	<input type="radio"/>
70		Injector Spill "2" Low side circuit Low - Cylinder 5	P1235		<input type="radio"/>	<input type="radio"/>
71		Injector Spill "2" Low side circuit High - Cylinder 5	P1236		<input type="radio"/>	<input type="radio"/>
72		Injector Spill "3" High side circuit Low - Cylinder 3	P1237	No Injection	<input type="radio"/>	<input type="radio"/>
73		Injector Spill "3" High side circuit High - Cylinder 3	P1238		<input type="radio"/>	<input type="radio"/>
74		Injector Spill "3" Low side circuit Low - Cylinder 3	P1239		<input type="radio"/>	<input type="radio"/>
75		Injector Spill "3" Low side circuit High - Cylinder 3	P1240		<input type="radio"/>	<input type="radio"/>
76		Injector Spill "4" High side circuit Low - Cylinder 6	P1241	No Injection	<input type="radio"/>	<input type="radio"/>
77		Injector Spill "4" High side circuit High - Cylinder 6	P1242		<input type="radio"/>	<input type="radio"/>
78		Injector Spill "4" Low side circuit Low - Cylinder 6	P1243		<input type="radio"/>	<input type="radio"/>
79		Injector Spill "4" Low side circuit High - Cylinder 6	P1244		<input type="radio"/>	<input type="radio"/>

NO.	ITEM	DTC DISRIPTION	P-CODE	FAIL SAFE & DEFAULT VALUE	WARNING LAMP	BUZZER
80	Injector	Injector Spill "5" High side circuit Low - Cylinder 2	P1245	No Injection	<input type="radio"/>	<input type="radio"/>
81		Injector Spill "5" High side circuit High - Cylinder 2	P1246		<input type="radio"/>	<input type="radio"/>
82		Injector Spill "5" Low side circuit Low - Cylinder 2	P1247		<input type="radio"/>	<input type="radio"/>
83		Injector Spill "5" Low side circuit High - Cylinder 2	P1248		<input type="radio"/>	<input type="radio"/>
84		Injector Spill "6" High side circuit Low - Cylinder 4	P1249	No Injection	<input type="radio"/>	<input type="radio"/>
85		Injector Spill "6" High side circuit High - Cylinder 4	P1250		<input type="radio"/>	<input type="radio"/>
86		Injector Spill "6" Low side circuit Low - Cylinder 4	P1251		<input type="radio"/>	<input type="radio"/>
87		Injector Spill "6" Low side circuit High - Cylinder 4	P1252		<input type="radio"/>	<input type="radio"/>
88		Injector Spill "1,3,5" High side circuit Low - Cylinder 1,2,3	P1253	No Injection	<input type="radio"/>	<input type="radio"/>
89		Injector Spill "1,3,5" High side circuit High - Cylinder 1,2,3	P1254		<input type="radio"/>	<input type="radio"/>
90		Injector Spill "2,4,6" High side circuit Low - Cylinder 4,5,6	P1255		<input type="radio"/>	<input type="radio"/>
91		Injector Spill "2,4,6" High side circuit High - Cylinder 4,5,6	P1256		<input type="radio"/>	<input type="radio"/>
92	Intake Temperature	Intake Air Temperature Sensor 1 Circuit Low Input	P0112	<ul style="list-style-type: none"> ▪ Sensor Default Value - Key on & Starting : - 10℃ - Driving : 50℃ 		
93		Intake Air Temperature Sensor 1 Circuit High Input	P0113			
94	System Voltage	System Voltage Low	P0562	Sensor Default Value : 28V	<input type="radio"/>	<input type="radio"/>
95		System Voltage High	P0563		<input type="radio"/>	<input type="radio"/>
96		Sensor Reference Voltage "B" Circuit Low	P0652	Sensor Default Value : 0V	<input type="radio"/>	<input type="radio"/>
97		Sensor Reference Voltage "B" Circuit High	P0653		<input type="radio"/>	<input type="radio"/>
98	Turbo Charger Speed	Turbocharger Turbine Overspeed	P0049	Engine Power Limitation	<input type="radio"/>	<input type="radio"/>
99		Turbocharger speed sensor circuit Low	P2580	Sensor Default Value : 100,000RPM	<input type="radio"/>	<input type="radio"/>
100		Turbocharger speed sensor circuit high	P2581		<input type="radio"/>	<input type="radio"/>
101	Starter Motor	Starter Relay Circuit	P0615		<input type="radio"/>	<input type="radio"/>
102		Starter Relay Circuit Low	P0616		<input type="radio"/>	<input type="radio"/>
103		Starter Relay Circuit High	P0617		<input type="radio"/>	<input type="radio"/>
104	Engine Oil Pressure	Engine Oil Pressure Low	-		<input type="radio"/>	<input type="radio"/>

CHAPTER 9
ANTI CORROSION SYSTEM

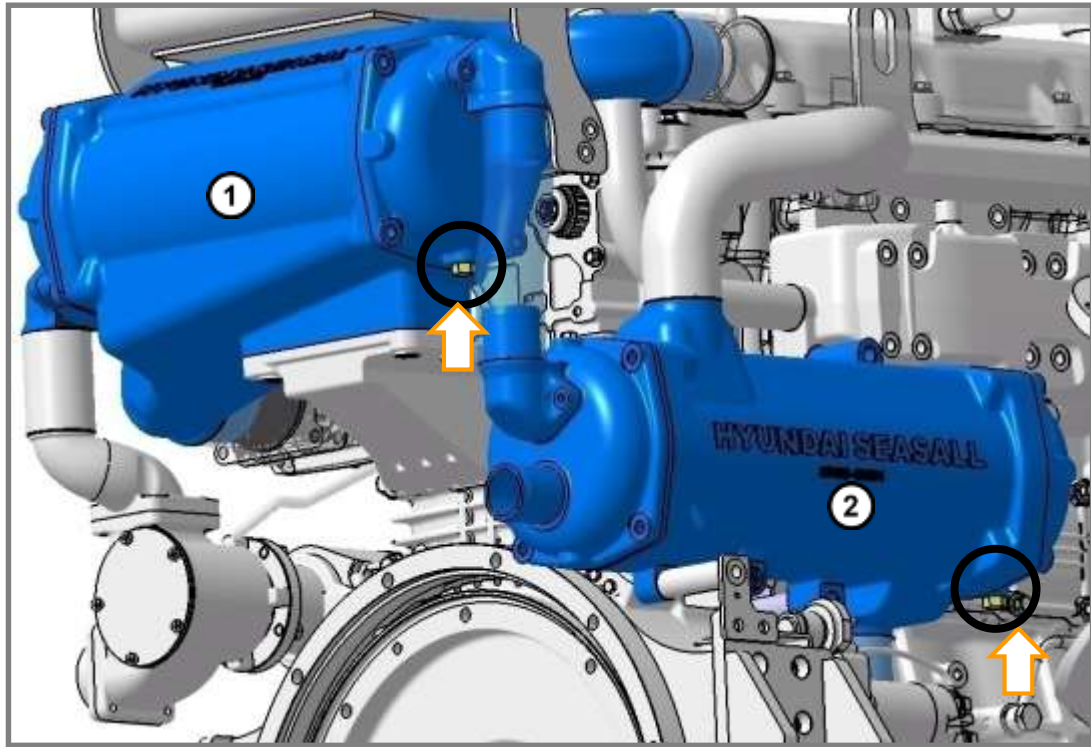

ANODE

- 1 INTERCOOLER** **2 HEAT EXCHANGER**

- 1) ANODE for corrosion protection. Must be replaced every 250 hours.
- 2) When used in salt or brackish water, regular inspection is required. It is strongly recommended to replace the sacrificial anode at the start of each season.



CAUTION

- DO NOT OPERATE ENGINE WITHOUT ANODES. IT IS HARMFUL TO YOUR ENGINE.
- CLOSE THE SEAWATER VALVE BEFORE REMOVING ANODES.
- MAKE SURE TO CHECK THE ANODE PLUG IN ACCORDANCE WITH THIS MANUAL.
- DO NOT LOOSEN COOLANT DRAIN PLUG.

CHAPTER 10 ENGINE STORAGE

The major consideration in preparing your engine for storage is to protect it from rust, corrosion, and damage caused by freezing of trapped water.

The following storage procedures should be followed to prepare your engine for out-of-season storage or prolonged storage (two months or longer and/or winter storage) :

CHECK LIST
• Visual inspection for leaks and damage
• Change engine oil and oil filter
• Replace fuel filter
• Check air filter element and clean if necessary
• Check engine coolant level and top up if necessary
• Check impeller and replace if necessary
• Check anodes and replace if necessary
• Clean the engine
• Flush and drain seawater cooling system
• Fill fuel tank until full and inspect the fuel system
• Remove the battery and store in a cool, dry place



CAUTION

FOR WINTER STORAGE, SEAWATER SHOULD BE DRAINED FULLY BY LOOSENING THE HEAT EXCHANGER ANODE. REFER TO CHAPTER 9.

WINTER STORAGE

Protect your engine from freezing and corrosion damage by following the procedures indicated below.

• LUBRICATION SYSTEM

- Start the engine and allow it to reach normal operating temperature.
- Turn off the engine. Drain the engine oil using the oil extraction pump. If the oil extraction pump is not installed, drain oil by removing the oil pan drain plug.
- Change the oil and oil filter and refill the engine with new oil according to technical maintenance specifications.
- Check the oil level on the dipstick and if necessary add more oil to reach the correct oil level.

• FUEL SYSTEM

- Check for fuel leaks where the line from the fuel tank connects to the engine. Tighten or replace the connection if necessary.
- Close the fuel valve. Clean the water separating fuel filter. Replace the filter element.
- After replacing the filter element, open the fuel valve to fill the entire fuel circulation line.
- Fill the fuel tank with fresh fuel to avoid condensation in the fuel tank.
- Close the fuel valve.

• COOLING SYSTEM

- Close the water valve.
- Connect a freshwater source to the seawater inlet. Run the engine at idle to flush all seawater out of the system.
- Fill the cooling system (seawater side) with a 30~50% solution of anti-freeze. Circulate into the seawater system by running the engine.

• COOLING SYSTEM

- If the seawater system is not filled with an antifreeze solution as per the instructions above completely drain the sea water system by removing the heat exchanger and intercooler anodes.
- Remove the sea water pump impeller and store in a dark place out of sunlight.
- Check all connections with inlet hoses. Tighten or replace the connection if necessary.
- Check the cooling system (heat exchanger, intercooler, thermostat, hoses, clamps, etc.) every 500 hours or every two years, whichever comes first. Replace any worn components.

• INTAKE SYSTEM

- Remove the air filter from engine.
- Clean the air filter.
- Intake part should be kept hermetically sealed.

• ELECTRICAL SYSTEM

- Disconnect the battery (-) cable to system ground
- Disconnect the battery (+) cable.
- Clean the battery cable and terminals.
- Coat the terminal connection with a battery terminal anti-corrosion agent.
- Whenever the battery will be stored for an extended period of time, be sure the cells are full of battery is fully charged.

LONG TERM STORAGE

These instructions must be followed in order to obtain warranty coverage for long term storage engines. These procedures are intended to prevent oxidation and deterioration of engine and fuel system components.

Engines stored for more than one (1) year must be inspected properly to ensure that they are in good condition.

- Engines used within one (1) year from factory release.
 - No specific action is required.

- Engines stocked more than one (1) year from factory release(To check every 6 months)
 - 1) Carefully inspect & check all parts for damage and/or corrosion.
 - 2) The coolant must be replaced for long term storage. *Use 50% Glycol containing anti-corrosion additives and 50% distilled water.*
 - 3) Check *all anodes* and replace if required.
 - 4) Storage conditions should be between 15~30⁰C and less than 50% relative humidity.

- Engines for use after long term storage and/or long term inactivity.
 - 1) Carefully inspect and check all parts for damage and/or corrosion.
 - 2) The coolant and lubricants must be replaced before using the engine.
 - 3) The oil filter and fuel filter must be replaced before using the engine.
 - 4) The seawater pump impeller must be replaced before using the engine.
 - 5) The thermostat and anodes must be checked and replaced if necessary
 - 6) Crank the engine without starting to lubricate the inside of the engine. Please disconnect the Crank Position Sensor to prevent engine start while lubricating the engine.
 - 7) Run the engine 10 minutes at idle RPM with no load before putting into service.
 - 8) Refer to Pre-Delivery checklist to inspect entire engine condition and installation.

**CHAPTER 11
MAINTENANCE**

THE INITIAL RUNNING CHECK

BEFORE THE WATER TEST

	Y	N
Seawater inlet valve open		
Engine coolant level		
Cooling system hose clamps tight		
Engine oil level		
Power steering fluid level		
Drive belt tension		
All electrical connections tight		
EOI warning system operation		
Battery fully charged and secured		
All fuel connections tight		
Exhaust system hose clamps tight		
Engine mounts tight		
Engine alignment		
Correct propeller rotation (Installed and torqued)		
Engine coolant and oil drain plug closed		
Throttle, shift and steering system fasteners tightened properly		
Boat drain plug in place (Check before putting boat in water)		

PROPULSION CHECKS

Steering operation throughout full range		
Forward - Neutral - Reverse gear proper operation		
Drive line components properly torqued		
Propeller nut torque		

ON THE WATER TEST

	Y	N
Seawater pump operating properly		
Seawater strainer correctly mounted , Clean and tightly closed		
Engine alignment (propulsion only)		
Fuel leaks		
Oil leaks		
Coolant leaks		
Water leaks		
Exhaust leaks and color		
EOI and gauges operating properly		
Engine emergency stop switch operating properly		
Idle RPM, within specifications		
WOT RPM, within specifications		

AFTER THE WATER TEST

Fuel, oil, coolant, water and fluid – no leaks		
Oil and fluid levels		
Propeller nut torque		

MAINTENANCE SCHEDULE

○ : Check/Clean, ◇ : Check (Replace if Necessary), ● : Replace

	Daily	250h	600h	1000h	Minimun 1 y /Necessary
Check coolant level and check for leaks 1)	○				
Clean Seawater strainer	○				
Check for Exhaust system leaks	○				
Check for Fuel system leaks	○				
Check the engine oil level and check for leaks	○				
Check the battery operating voltage	○				
Check the oil level and check the steering system for leaks	○				
Check transmission lubrication level and the propulsion system ²⁾ for leaks	○				
Engine oil and filter ³⁾		●			◇
Check the sacrificial anodes ¹⁾ Anti corrosion system		●			◇
Check hose clamps for tightness and corrosion		◇			◇
Check the electrical system for tight connections		◇			◇
Check tightness of the bolts, nuts and other fasteners		◇	●		◇
Fuel filter and water separator		◇	●		◇
Air filter		◇	●		◇
Drive belt			◇		◇
Heat exchanger tube bundle			◇		◇
Inter-cooler tube bundle			◇		◇
Checking Inter-cooler automatic drain valve			◇		◇
Replace the seawater pump impeller			◇	●	◇
Turbocharger				◇	◇

1) Replace the coolant every two years.

2) For detailed propulsion system information, refer to the manufacturer's manual.

3) Replace the engine oil after the first 100 hours of operation.



CAUTION
YOU SHOULD EXERCISE THE UTMOST CARE TO PREVENT INJURY TO YOURSELF OR ENGINE DAMAGE WHENEVER PERFORMING ANY MAINTENANCE OPERATIONS.

A/S PART NUMBER

P/N	DESCRIPTION	Qty	Remarks
05300-6L171	ELEMENT-OIL FILTER	1	
05360-6L171	FILTER CATRIDGE-FUEL	1	
31945-7L002	ELEMENT-WATER SEPARATOR	1	
00500-6L170	AIR FILTER	1	
00400-6L160	SEAWATER PUMP ASSEMBLY	1	
00400-4H290	IMPELLER KIT	1	
00400-4H298	MINOR KIT-SEAWATER PUMP	1	
00400-4H299	MAJOR KIT-SEAWATER PUMP	1	
00100-4H102	ANODE	2	
00300-1A004	ENGINE OIL(GENUINE ORIGINAL EQUIPMENT CI-4 , 4L)	11	
25210-84401	V-RIBBED BELT	1	

CHAPTER 12
TROUBLESHOOTING GUIDE

■ **Starter motor does not crank the engine**

Possible Causes	
•Engine stop switch is not in the “ON” position (Switch is pressed)	•Engine is not shifted to neutral position
•Weak battery or battery connections are loose or corroded	•Starter motor solenoid or slave solenoid failure
•Ignition key switch failure	•Defective EOI fuse (3A)
•Wiring or electrical connection fault	•Defective ECU

■ **Engine cranks but does not start**

Possible Causes	
•Weak battery or bad starter motor	•Low fuel pressure
•No fuel	•Low compression pressure
•ECU not functioning	•Crank position sensor not functioning
•Incorrect starting procedure	•Fuel is not reaching the engine
•Faulty fuel filter or electric fuel pump	•Bad fuel quality or water in fuel
•Faulty fuse	•Faulty injector

■ **Engine starts with difficulty or starts and stalls**

Possible Causes	
•Low fuel pressure in fuel rail	•Faulty alternator or voltage regulator
•Leakage in high pressure fuel circuit	•No engine coolant temperature sensor signal
•Faulty fuse	•Low battery voltage
•No rail pressure sensor signal	•Low compression pressure
•Oil level too high or too low	•Clogged fuel filter
•ECU program error or hardware fault	

■ **Engine idle is rough**

Possible Causes	
•No rail pressure sensor signal	•Low compression pressure
•Wiring harness open or poor connection	•Faulty high pressure fuel pump
•Bad fuel quality or water in fuel	•Faulty injector
•Clogged fuel filter / air filter	•Carbon deposit on the injector

■ **Engine rattling, noisy engine**

Possible Causes	
•Incorrect compensation of individual injectors	•No engine coolant temperature sensor signal
•Low compression pressure	•Clogged injector return line
•No rail pressure sensor signal	•Faulty injector
•Poor injector O-ring	•Carbon deposit on the injector

■ **Uneven acceleration / deceleration**

Possible Causes	
•Intermittent faulty fuel line connection	•Oil suction
•No rail pressure sensor signal	•ECU program error or hardware fault
•Leakage in intake system	•Damaged turbocharger or leakage in vacuum line
•Clogged fuel filter	•Low compression pressure
•Leakage in high pressure fuel circuit	•Injector needle stuck

■ **Engine stops**

Possible Causes	
•Out of fuel	•Crank signals missing
•Fuel feed line not connected	•Fuel pressure regulator valve contaminated, stuck, jammed
•Leakage in high pressure fuel circuit	•Rail pressure regulator valve contaminated, stuck, jammed
•Fuel out of specification	•Faulty alternator or voltage regulator
•Bad fuel quality or water in fuel	•Faulty high/low pressure fuel pump
•Clogged low pressure fuel circuit	•ECU program error or hardware fault

■ **Performance loss**

Possible Causes	
•Incorrect compensation of individual injectors	•Leakage at the injector
•Clogged air filter	•Fuel or intake air temperature too high
•Oil level too high or too low	•Engine coolant temperature too high
•Damaged turbocharger or intake air leakage	•Low compression pressure
•Clogged fuel filter	•Poor valve clearance

CHAPTER 13 WARRANTY

HYUNDAI SEASALL RATING CATEGORIES FOR MARINE ENGINE

S5 : Pleasure Duty

- Full power operation restricted to within 10% of total use period
 - * Continuous maximum output restricted to 0.5 hours within 12 hours period
- Cruising speed (RPM) at engine RPM < 90% of rated speed (RPM)
- Operating less than 400 hours per year

S4 : Special Pleasure Duty / Special Light Duty Commercial

- Full power operation restricted to within 10% of total use period
 - * Continuous maximum output restricted to 1 hours within 12 hours period
- Cruising speed (RPM) at engine RPM < 90% of rated speed (RPM)
- Operating less than 1,000 hours per year

S3 : Light Duty Commercial

- Full power operation restricted to within 20% of total use period
 - * Continuous maximum output restricted to 2 hours within 12 hours period
- Cruising speed (RPM) at engine RPM < 90% of rated speed (RPM)
- Operating less than 1,500 hours per year

S2 : Medium Duty Commercial

- Full power operation restricted to within 30% of total use period
 - * Continuous maximum output restricted to 4 hours within 12 hours period
- Cruising speed (RPM) at engine RPM < 90% of rated speed (RPM)
- Operating less than 3,000 hours per year

S1 : Heavy Duty Commercial

- Uninterrupted and unlimited use at full power.

APPLICATION OF WARRANTY COVERAGE

Warranty coverage is available only to retail customers who purchase from a dealer authorized by Hyundai SeasAll to distribute the product in the country in which the sale occurred, and then only after the Hyundai SeasAll specified pre-delivery inspection process is completed and documented. Warranty coverage becomes available upon proper registration of the product by the authorized dealer. Routine maintenance outlined in the Installation and Operation Manual must be performed in a timely fashion in order to obtain warranty coverage. Hyundai SeasAll reserves the right to make any warranty coverage contingent upon proof of proper maintenance.

This warranty may be rendered invalid at Hyundai SeasAll's discretion based upon:

- 1) Modifications not authorized by Hyundai SeasAll
- 2) Handling errors
- 3) Improperly performed Pre-Delivery Inspection
- 4) Unsuitable fuels, coolant or lubricants
- 5) Using the engine outside of the specified duty cycle rating
- 6) Overloading
- 7) Improperly performed repairs
- 8) Improper maintenance interval(s)
- 9) No submitted Pre-Delivery Inspection Card and Warranty Registration Card

DURATION OF WARRANTY

Leisure Applications

Engine	Rating	Base Engine		Extended Major Components (Includes Base Engine Warranty)	
		year	hour	year	hour
S270/D170/R200 /U125	S5	2	1,000	4	2,000
**H380/L500	S5	2	-	4	5,000

** Operating less than 1,500 hours per year and Full Power operation < 10% of total use period

- Warranty period is limited by Years or Hours whichever occurs first.
- Major Components : Engine Block Casting, Crankshaft Forging, Connecting Rods, Camshaft Forging, Transmission Cover/Housing, Flywheel Housing, Intake Manifold, Fresh Water Pump Housing and Oil Pan.
- Cylinder Liner or Cylinder Bore scratches are not included in extended major part warranty coverage.

Commercial Applications

Engine	Rating	Base Engine		Extended Major Components (Includes Base Engine Warranty)	
		years	hours	years	hours
S270/D170/R200 /U125	S4	1	1,000	3	2,000
S220/D150/L700	S3	1	1,500	3	6,500
L600	S2	1	3,000	3	6,000
H380/L500	S1	1	5,000	3	10,000
M70/M100/M140					
Q280/Q330/Q38 5/Q405					

- Warranty period is limited by Years or Hours whichever occurs first.
- Major Components : Engine Block Casting, Crankshaft Forging, Connecting Rods, Camshaft Forging, Transmission Cover/Housing, Flywheel Housing, Intake Manifold, Fresh Water Pump Housing and Oil Pan.
- Cylinder Liner or Cylinder Bore scratches are not included in extended major part warranty coverage.

Hyundai SeasAll Rating Categories For Marine Auxiliary Engine

(Ratings in accordance with ISO 8528)

Standby Power

- 1) Operating less than 500 hours per year with average 90% load of the declared Standby Power
- 2) No overload capability is available for this rating.

Prime Power

- 1) Average power operation is not exceed 70% of the declared Prime Power.
- 2) A 10% overload is permissible for 1 hour per 12 hours of operation.
- 3) Maximum prime power shall not exceed 500 hours per year.

Marin Auxiliary Engine

Engine	Rating	Base Engine		Extended Major Components (Included Base Engine Warranty)	
		year	hour	year	Hour
H10G / L13G	Standby Power	2	1,000	4	3,000
	Prime Power	1	-	3	10,000

Genset

Model		Warranty Classification	
		Prime Power	Standby Power
50 HZ 1,500 RPM 220V * 3P	M35GS/ M43GS / M56GS	1year	2 years/ 1000 hours
	Q150GS/ Q176GS/ Q210GS/ Q230GS		
60 HZ 1,800 RPM 220V * 3P	M40GS/ M55GS/ M70GS		
	Q165GS/ Q200GS/ Q230GS/ Q270GS		

WARRANTY STARTING DATE

Warranty Begins:

- 1) When engine is delivered to the first retail purchaser
- 2) When the engine is first leased or rented
- 3) When the products reaches the first day of the 7 month after the product has been shipped from Hyundai SeasAll, the warranty date will be started automatically. If you submit the "Pre-Delivery Inspection Card" and "Warranty Registration Card", the starting date can be changed to the date on your documents.

WARRANTY REGISTRATION

Warranty Registration Card must be submitted to Hyundai SeasAll within 30 days of the Warranty Starting Date. The Warranty Registration Card identifies information on customer and product, models and serial numbers, date of sale, type of use and the selling dealer etc. If the 'Warranty Registration Card' and 'Pre-Delivery Inspection Card' are not approved or not submitted to Hyundai SeasAll within 30 days from Warranty Starting Date , Hyundai SeasAll reserves the right to decline warranty reimbursement.

TRANSFER OF WARRANTY COVERAGE BETWEEN OWNERS

This limited warranty is transferable to a subsequent purchaser, but only for the remainder of the unused portion of the limited warranty. To transfer the warranty to the subsequent owner, the revised “Warranty Registration Card” and “Pre-Delivery Inspection Card” should be submitted to Hyundai SeasAll’s distributor or dealer. Upon processing the transfer of warranty, Hyundai SeasAll will verify the warranty registration of the new owner.

WHAT HYUNDAI SEASALL WILL DO

Hyundai SeasAll will pay for all parts and labor needed to repair the damage to the product resulting from a defect in materials or factory workmanship.

The warranty does not apply to any damage or defect that is the result of abnormal use or carelessness.

The repair or replacement of parts, or the performance of service under this warranty does not extend the life of this warranty beyond its original expiration date.

OWNER’S OBLIGATIONS

It is the owner’s obligation to install, operate, maintain and care for Hyundai SeasAll engines in accordance with the instructions and requirements stated in the Installation and Operation Manual.

The owner is responsible for providing enough time and cooperation to get the engine repaired by an authorized dealer, and to deliver it to a proper facility for repair.

The owner is responsible for the cost for warranty inspection, including hauling out, launching and transportation.

BUSINESS PARTNER’S OBLIGATIONS

It is Hyundai SeasAll’s Distributor and/or Dealer’s responsibility to support the retail customer with prompt diagnosis and repair whether or not the engine was sold by the servicing dealer or by the Distributor responsible for the territory.

It is Hyundai SeasAll’s Distributor’s responsibility to communicate all warranty issues to the factory in a timely manner so that they can be quickly resolved.

HOW TO OBTAIN WARRANTY COVERAGE

The customer must provide Hyundai SeasAll with a reasonable opportunity to repair the engine, as well as reasonable access to the product for warranty service. Warranty claims shall be made to a Hyundai SeasAll Authorized Repair Facility to service the product. Purchaser shall not, unless requested by Hyundai SeasAll, ship the product or parts of the product directly to Hyundai SeasAll. The warranty registration card is the only valid registration identification and must be presented to the dealer at the time warranty service is requested in order to obtain coverage.

WHAT IS COVERED

Hyundai SeasAll warrants its products to be free of defects in material and workmanship during the warranty period.

LIMITATIONS – EXPENDABLE PARTS

Not included are the following expendable parts:

- Filters : fuel filter, engine oil filter, air filter
- Lubricants : engine oil, coolant, power steering oil.
- Rubber products : seawater pump impeller, rubber hoses, belts, engine coupler, rubber isolation mounts, bellows.
- Gaskets, anodes.

WHAT IS NOT COVERED

- Fuel injector or filter cleaning
- Belt, cable adjustments or lubrication checks made in connection with normal services.
- Damage caused by neglect, lack of maintenance, accidents, abnormal operation, improper installation or service, unapproved modifications or freezing temperatures.
- Haul-out (crane), launching or towing charges, removal and/or replacement of boat partitions or material for necessary access to the product, all related transportation charges and/or travel time, etc.
- All incidental and/or consequential damages (storage charges, telephone or rental charges of any type, inconvenience or loss of time or income) are the owner's responsibility.
- Use of other than Hyundai SeasAll genuine replacement parts when making warranty repairs.
- Participating in or preparing for racing or other competitive activity.
- Water entering the engine via the air inlet filter or exhaust system or submersion. Water in the starter motor.
- Failure of any parts caused by lack of cooling water.
- Damage caused by blockage of the cooling system by foreign matter.
- Use of fuels and lubricants that are not suitable for use with or on the product as specified in the Installation and Operation Manual.
- Normal wear and tear
- Storage damage (partially painting scratch)
- Cost resulting from ineffective or repeated repairs; improper repairs due to misdiagnosis.
- Owner's personal cost (indirect loss) resulting from maintenance

TRANSMISSION AND STERNDRIVE WARRANTIES

Transmissions and drive systems (ZF Marine, Mercury etc.) are covered under separate warranties, provided and serviced by those companies. For information on those warranties, please see the separate booklets included in the original packaging of your Hyundai SeasAll purchase.

This card is essential for registration of the customer's warranty.
 Please fill out the following registration card in English.

Date of sale

Month	Day	Year

If Warranty Transfer , Check box

OWNER'S INFORMATION

Name or Company		E-Mail Address	
Country		State / Province / City	
Operating Location			

DEALER INFORMATION

Dealer / Installer		Distributor Name	
City		E-Mail Address	

ENGINE INFORMATION

Number of Engines	Single <input type="checkbox"/>	Dual <input type="checkbox"/>
-------------------	---------------------------------	-------------------------------

Engine Model		Gear Model	
Engine Serial No.		Gear/Drive Serial No.	
		Transom Serial No.	

Engine Model		Gear Model	
Engine Serial No.		Gear/Drive Serial No.	
		Transom Serial No.	

BOAT INFORMATION

REPOWER

Manufacturer		Material	Steel <input type="checkbox"/>	Alu. <input type="checkbox"/>	FRP <input type="checkbox"/>	Wood. <input type="checkbox"/>	
Model		LOA		ft	Beam		ft
Boat Type		Hull ID					
Type of Use	Pleasure <input type="checkbox"/>	Commercial <input type="checkbox"/>	Planning <input type="checkbox"/>	Semi Disp. <input type="checkbox"/>	Displacement <input type="checkbox"/>		

Dealer's Instructions: Dealers must complete this card to register the warranty. Please return the copy to your national Importer/Distributor immediately. Unregistered engines are subject to warranty rejection.

REMARKS

SIGNATURE : _____

